

**EEL4914: Senior Design 1 - Summer 2020**

*University of Central Florida*

*Department of Electrical and Computer Engineering*

# **Automated Rescue Vehicle (A.R.V.)**



July 28th, 2020

**Group Number: 7**

**Group Members**

Bernardo Correa - Electrical Engineering

Malik Santos - Electrical Engineering

Dariel Tenf - Computer Engineering

Samuel Frisco - Electrical Engineering

# Table of Contents

List of Figures .....	vii
List of Tables .....	ix
1.0 Executive Summary .....	1
2.0 Project Description .....	2
2.1 Motivation .....	2
2.2 Background .....	2
2.3 Goal .....	3
2.4 Related Projects .....	3
2.4.1 Arduino GPS Drone RC Boat .....	3
2.4.1.1 A.R.V Comparison to Drone RC Boat .....	4
2.4.2 Roboat .....	5
2.4.3 SeaCharger .....	6
2.5 Requirements Specifications .....	7
2.5.1 Engineering Requirement Summary Table .....	10
2.6 House of Quality Matrix .....	11
2.7 ARV Block Diagram .....	12
2.7.1 Block Status .....	13
3.0 Research and Part Selection .....	14
3.1 Relevant Technologies .....	14
3.1.1 DC-DC Converter and Voltage Regulator .....	14
3.1.1.1 Integration .....	14
3.1.1.2 Converter Comparisons .....	15
3.1.2 Motors .....	17
3.1.2.1 Integration .....	17
3.1.2.2 Motor Comparisons .....	17
3.2 Software Technologies and Investigations .....	19
3.2.1 What is Digital Image Processing? .....	19

3.2.2	What is Machine Learning? .....	20
3.2.3	What is Vehicle Automation? .....	21
3.2.4	ROS .....	22
3.2.5	C++ .....	22
3.2.6	Python .....	22
3.2.7	MOOS-IvP .....	23
3.2.8	PID Controller .....	23
3.3	RC Boat .....	24
3.3.1	URUAV 2011-5 Generation .....	24
3.3.2	Spartan Race Boat .....	24
3.3.3	Fish Catching RC Boat .....	25
3.3.4	Flytec 2011-5 .....	25
3.4	Microcontrollers .....	27
3.4.1	Overview .....	27
3.4.2	Texas Instruments MSP430 Series .....	27
3.4.3	Raspberry Pi .....	29
3.4.3.1	Connections.....	30
3.4.3.2	Power Options .....	30
3.4.3.3	Display Options .....	30
3.4.4	STM32 Series .....	31
3.4.5	Microcontroller Integration .....	33
3.5	Depth Sensor .....	34
3.5.1	Goal .....	34
3.5.2	Technology .....	34
3.5.3	SM111 Transducer .....	35
3.5.4	Depth Sensor Comparisons .....	38
3.5.4.1	SM111 Piezo Transducer .....	38
3.5.4.2	PARALLAX 28015 .....	39

3.5.4.3	GP2Y0A21YK0F IR Sensor .....	40
3.5.4.4	Depth Sensor Comparison Summary .....	41
3.5.5	Depth Sensor Waterproofing .....	41
3.6	Camera .....	43
3.6.1	Camera Options .....	43
3.6.1.1	Eachine TX06 FPV Camera .....	43
3.6.1.2	Raspberry Pi Camera Module v2 .....	44
3.6.1.3	FPV Foxeer Razer Micro Camera .....	46
3.6.2	Camera Comparison Summary .....	46
3.6.3	Water Proof Casing for Camera Module .....	47
3.7	GPS .....	48
3.7.1	Overview .....	48
3.7.2	Neo 6m GPS Module .....	48
3.7.3	Pharos GPS 360 .....	49
3.7.4	Particle Boron LTE and Adafruit Featherwing.....	49
3.7.5	GPS Comparison Summary .....	49
3.8	Boat Battery .....	50
3.8.1	Technologies .....	50
3.8.1.1	Portable Power for the Raspberry Pi .....	52
3.8.2	PiJuice HAT .....	53
3.8.3	MakerFocus Raspberry Pi 4 Battery Pack .....	53
3.8.4	MakerHawk Raspberry Pi UPS HAT .....	55
3.9	TensorFlow .....	56
3.9.1	Tensorflow and Raspberry Pi .....	56
3.9.2	Image Processing with Tensorflow .....	57
3.10	Wireless Live Video Streaming .....	58
3.10.1	Video Streaming to a Display .....	58
3.10.2	Display/Monitor Options .....	58

3.10.2.1	Five Inch TFT Display .....	58
3.10.2.2	Iphone/ Android/ PC Display .....	59
3.11	Bluetooth Connection.....	59
3.12	UART .....	61
3.13	Wi-Fi .....	61
3.14	Static IP address vs. Dynamic IP address .....	62
4.0	Standards and Design Constraints .....	63
4.1	Related Standards .....	63
4.1.1	1679.1 Evaluation of Lithium Based Batteries .....	63
4.1.2	Battery Standard Design Impact .....	64
4.1.3	12207-2017- Software Development Standard.....	65
4.1.4	1609.0 Wireless Access in Vehicular Environments .....	66
4.1.5	Wireless Access Standard Design Impact .....	67
4.1.6	IPC - PCB Standard (Printed Circuit Board) .....	68
4.2	Design Constraints .....	68
4.2.1	Economic and Time Constraints .....	69
4.2.2	Environmental, Social, and Political Constraints .....	69
4.2.3	Ethical, Health and Safety Constraints .....	70
4.2.4	Manufacturability Constraints .....	72
4.2.5	Sustainability Constraints .....	72
5.0	Hardware and Software Design .....	73
5.1	Power .....	73
5.2	System Components Power .....	73
5.3	DC-DC Converter 3.3V .....	75
5.3.1	Regulator Testing .....	79
5.4	Motor Control Design .....	79
5.5	GPS Design and Integration .....	81
5.6	Depth Sensor Design and Integration .....	82

5.6.1 Microcontroller Integration .....	82
5.6.2 Oscillation and Power Amplification .....	83
5.7 Raspberry Pi and Camera Design .....	84
5.8 Wifi Module Design .....	85
5.8.1 ESP8266 Wi-Fi Module .....	85
5.9 Component Breadboard Testing .....	86
5.9.1 Overview .....	86
5.9.2 JBtek Power Supply and Motor Driver .....	87
5.9.3 Makerfocus Raspberry Pi Battery Pack Test .....	88
5.9.5 Raspberry Pi Camera Module v2 Testing .....	89
5.9.6 GPS Testing .....	91
5.10 Overall Schematic .....	92
5.10.1 Complete Schematic .....	95
5.11 Software Design and Flowchart .....	97
5.11.1 Software Design .....	97
5.11.2 Development Approach .....	98
5.11.3 Programming Tools .....	99
5.11.3.1 Integrated Development Environment .....	99
5.11.3.2 Version Control System .....	100
5.11.4 Sensors .....	101
5.11.5 GPS Module .....	102
5.11.6 Camera .....	103
5.12 Streaming on VLC Media Player .....	104
5.12.1 Streaming on Browser (http) .....	105
5.13 Setting Up a Static IP Address .....	106
5.14 User Interface .....	106
6.0 Integration, PCB, and System Testing .....	108
6.1 Overall Integration .....	108

6.2 PCB Design .....	108
6.3 Project Prototype Illustration .....	110
6.4 Project Operation Manual .....	112
6.4.1 Setup Process .....	112
6.4.1.1 Setting up A.R.V. Wi-Fi Network .....	113
6.4.1.2 Steps for Normal Operation .....	113
6.4.1.3 Step for Charging the A.R.V. ....	114
6.5 System Testing .....	114
6.5.1 Level 1 Testing .....	114
6.5.2 Level 2 Testing .....	115
6.5.3 Level 3 Testing .....	115
6.5.4 Level 4 Testing .....	115
6.5.5 Level 5 Testing .....	116
6.5.6 Level 6 Testing .....	116
6.5.7 Level 7 Testing .....	116
6.5.8 Level 8 Testing .....	116
6.5.9 Level 9 Testing .....	117
7.0 Administration .....	118
7.1 Suppliers .....	118
7.2 Estimated Project Budget and Financing .....	119
7.2.1 Estimated Additional Costs .....	120
7.3 Project Milestone for both semesters .....	121
8.0 Conclusion .....	122
9.0 Appendix .....	124
9.1 Bibliography .....	124
9.2 Permissions .....	128

## List of Figures

Figure 1: Arduino GPS Drone RC Boat .....	4
Figure 2: Two Roboats linking together .....	5
Figure 3: Sample image of Roboats linking to form a bridge .....	6
Figure 4: Sea Charger sailing at sea .....	7
Figure 5: House of Quality Matrix .....	11
Figure 6: Initial System Design Block Diagram .....	12
Figure 7: Internal and external circuit for linear regulator .....	15
Figure 8: Switching Regulator Circuit .....	16
Figure 9: DC Brushed Motor .....	18
Figure 10: AC Brushless Motor .....	18
Figure 11: Flytec 2011-5 .....	25
Figure 12: MSP430 Microcontroller .....	29
Figure 13: Raspberry Pi 4 Microcontroller .....	30
Figure 14: STM32 Series Microcontroller .....	32
Figure 15: Sonar technology 1942 – 2020 .....	34
Figure 16: Sonar technology 1942 – 2020 .....	34
Figure 17: SM111 Transducer .....	35
Figure 18: Camera Module and Raspberry Pi Board flex cable .....	45
Figure 19: Waterproof casing for camera module .....	47
Figure 20: PiJuice HAT battery pack .....	53
Figure 21: Raspberry Pi Battery Pack .....	54
Figure 22: Battery Capacity .....	54
Figure 23: MakerHawk UPS HAT Battery Pack .....	55
Figure 24: Index Mapping for TensorFlow .....	57
Figure 25: DC-DC Converter Schematic 3.3V Output .....	76
Figure 26: Regulator Input and Output Loads Diagram .....	76



<b>Figure 27: Diagram for Regulator Testing Requirement .....</b>	<b>79</b>
<b>Figure 28: Motor Interface Design Block Diagram .....</b>	<b>81</b>
<b>Figure 29: GPS Interface Block Diagram .....</b>	<b>82</b>
<b>Figure 30: Depth Sensor Schematic Diagram .....</b>	<b>83</b>
<b>Figure 31: Raspberry Pi Interface Design Block Diagram .....</b>	<b>85</b>
<b>Figure 32: Wifi Module Interface Design .....</b>	<b>85</b>
<b>Figure 33: All Major Components for Testing .....</b>	<b>86</b>
<b>Figure 34: Power Supply, Motor Driver, and Propeller Test .....</b>	<b>87</b>
<b>Figure 35: Battery Pack Testing .....</b>	<b>89</b>
<b>Figure 36: Camera Module v2 Test .....</b>	<b>90</b>
<b>Figure 37: GPS Module Testing .....</b>	<b>91</b>
<b>Figure 38: GPS Coordinates sent from Module testing .....</b>	<b>92</b>
<b>Figure 39: Eagle Software .....</b>	<b>93</b>
<b>Figure 40: Component Footprint Software .....</b>	<b>94</b>
<b>Figure 41: Overall Schematic using Eagle .....</b>	<b>97</b>
<b>Figure 42: Sensor Software Flowchart .....</b>	<b>102</b>
<b>Figure 43: GPS Module Software Flowchart .....</b>	<b>103</b>
<b>Figure 44: Camera Software Flowchart .....</b>	<b>104</b>
<b>Figure 45: User Interface Block Diagram .....</b>	<b>107</b>
<b>Figure 46: PCB Layout and Wired Connections .....</b>	<b>110</b>
<b>Figure 47: Design Illustration .....</b>	<b>111</b>

## List of Tables

Table 1: Arduino GPS RC Boat VS. ARV .....	4
Table 2: Main System Requirements with specific values .....	10
Table 3: DC-DC Comparison Table .....	16
Table 4: RC Boat Comparison for Selection .....	26
Table 5: MSP430 Data .....	28
Table 6: Raspberry Pi 4 Data .....	31
Table 7: STM32 Data .....	32
Table 8: Microcontroller Comparison .....	33
Table 9: Data Sheet for the SM111 .....	36
Table 10: Data Sheet for the Piezoelectric Material .....	37
Table 11: Data table for SM111 Comparison .....	38
Table 12: Data table for PARALLAX 28015 Comparison .....	39
Table 13: Data table for GP2Y0A21YK0F IR Sensor .....	40
Table 14: Comparison and Selection of Depth Sensor .....	41
Table 15: VytaFlex 20 Technical Overview .....	42
Table 16: Eachine TX06 FPV Camera Specifications and Features .....	44
Table 17: Raspberry Pi Camera Module v2 Specifications and Features ....	45
Table 18: Camera Comparison for Selection .....	47
Table 19: GPS Module Comparison and Selection .....	50
Table 20: Comparison Between Battery Types .....	51
Table 21: Consumption and Power of Raspberry Pi .....	52
Table 22: Battery Comparisons for Selection .....	56
Table 23: Ranges of Bluetooth Devices by Class .....	60
Table 24: Powered Components in the A.R.V System .....	74
Table 25: BOM for DC-DC Converter .....	77
Table 26: Operating Values for DC-DC Converter .....	78
Table 27: Sprints and Products .....	99

<b>Table 28: Suppliers List for all Components .....</b>	<b>118</b>
<b>Table 29: Estimated Item Cost .....</b>	<b>119</b>
<b>Table 30: Additional Items for Boat Haul Method .....</b>	<b>120</b>

# 1.0 Executive Summary

Stranded at sea. For some it is a fantastic adventure, for others it is their greatest fear. Disasters at sea prove to be the most daunting challenges for rescue parties, so much that a branch of the U.S. military has dedicated teams and equipment for this task. What comes to mind is a US Coast Guard diver jumping from a helicopter and emerging with a rescued voyager, tied together to a crane cable, but in order to achieve this dramatic image of relief, rescue teams must first locate what amounts to a needle in an incomprehensibly big haystack. The ocean tragically claims the lives of 2,000 seavoyagers every year. Commercial fishing and shipping are considered among the most dangerous jobs in the world. There are also tens of millions of smaller, private vessels that take to the seas for fishing, recreation, and business. This makes for a web of traffic that is far less regulated than air or land travel. This web, and the harsh conditions constantly seen in all oceans produce a navigation challenge that takes years of experience to overcome and decades to master. Topwater waves can reach heights exceeding 70 feet, and extreme wind and rain must always be considered in sea travel. Ocean weather alone can tell many cautionary tales, but disaster also strikes with equipment malfunction. Rudders or propellers can be damaged, or an iceberg could be hit. This leaves passengers and crew members either in the water, or in emergency life vessels, ill equipped for extended survival at sea.

The ocean is in constant motion. The only reference point rescue teams have is the last recorded GPS signal of the vessel prior to disaster. From this clue, it is a matter of sharp eyes and luck to locate survivors that may have drifted miles from the location of the shipwreck. It is here that the A.R.V. steps in to offer assistance. It will be an addition to a rescue tool box consisting of teams on the water, in the air, and on land providing communication and guidance. The object detection will look for persons, debris, or airborne flares and give a degree of certainty that what it is seeing is of interest to the rescue team. Under the operating conditions we intend to implement the A.R.V. in every set of eyes, human or not, counts. The journey of this project will be governed by certain industry standards and design constraints, which will be outlined throughout this report. The report will set quantitative goals for all aspects of the A.R.V., from battery life to environment capabilities and size restrictions. It will provide a detailed record of the component selection process, and research into relevant technologies, related projects and helpful resources. The report will explore the logic of the code requirements, as well as Machine Learning, Object Detection, and Image Processing concepts. Above all else and as with any engineering project, safety will govern decision making to the highest degree. The A.R.V. will respond to disasters, and will not be designed in a manner to risk another disaster if a malfunction occurs. As an independently funded project, cost will be in heavy consideration with the selection of each component.

## 2.0 Project Description

### 2.1 Motivation

Mankind has made its most significant advancements by satisfying our need to explore what we do not understand. Our *curiosity* has allowed us to discover amazing new technologies and physical understanding, hence the namesake of one of the greatest exploration projects in human history. From wooden ships crossing oceans to metal rockets crossing solar systems, it has never been satisfactory to not know and simply conjure a guess. Our need to learn will continue to propel us to an enlightened future, however it will also continue to expose us to new and potentially dangerous environments.

Water is one of the great unknowns to mankind. It is the one place that humans venture where we are entirely unequipped for survival. As depth increases, light fades, and the world below becomes more strange and unobserved. In water lies foreign creatures and unknown hazards. There are many ways a person could be left to survive in the ocean: left behind on a scuba trip, falling overboard, or a shipwreck. Finding someone lost at sea is an arduous and unfortunately often hopeless endeavour. Authorities like the Coast Guard and other search parties need any help to tip the scales in their favor, and we are in the age of technology providing that help.

It is the directive of this project to provide a lightweight, portable solution to this problem. We will build a system that actively seeks and analyzes objects in water in an effort to identify subjects that would interest search parties at sea. It will implement image processing and object detection with the use of LIDAR and conventional camera technology. There will be a layer of autonomous decision making to allow an extra set of eyes (the operator) to scan the water while the system assists in the effort.

### 2.2 Background

Large scale sea travel has existed for the past 5,000 years. Ships at sea have evolved in role from simply trade vessels to also military, police, and recreation. At any given moment, there are around 50,000 merchant ships alone at sea. This modern marvel is an unfortunate opportunity for disaster to strike. In this case of disaster, there are often scores of small boats and helicopters that are deployed to locate shipwrecks, survivors, and debris. This can also apply to plane crashes over large bodies of water. The core function of this project is to provide machine assistance to the search effort by detecting objects of interest and alerting the user upon discovery.

The past ten years have seen a huge surge in devices that provide air exploration to any user. The “drone” is a weekend hobby, essential tool for law enforcement, and even a weapon. While the aerial drone market floods, there are few options for similar underwater exploration. The term underwater exploration typically conjures thoughts of miniature submarines visiting the Titanic and pirate wrecks, but what about a system to collect the most essential readings of a body of water? These readings are its depth, temperature, and contents, and will be the core functions of this project.

## **2.3 Goal**

The overall goal of our automated rescue vehicle is to provide an efficient foolproof way of detecting a person in need of help in a body of water. For large scale use, this rescue vehicle can be used for detection of many other objects and for other needs. However, the necessary goal for our design project is to be able to accurately detect a person in the water. Once detected by the rescue vehicle, the user that is operating the boat will be able to see live video feed of the detection. A GPS location will be displayed at all times on the screen so that when a person has been detected, the user will know its exact location.

Quality goal is important for this project and we will provide the design with an efficient power design that provides for over 2 hours of use without recharging the battery. Large scale goals outside of our project design would use a much bigger and long term battery. Lastly, our goal is to provide the user with sufficient safety data of the boat's environment by providing continuous depth readings from the on board depth sensor.

## **2.4 Related Projects**

### **2.4.1 Arduino GPS Drone RC Boat**

The Arduino GPS Drone RC Boat is a GPS-controlled, camera-equipped RC boat, as pictured below, with an Arduino Mega and 433 MHz remote. It's a drone boat controlled by an Arduino Mega. Like our project, it's designed to be capable of navigating a body of water autonomously. The control is transmitted via 433 MHz serial transceiver modules, the software is written in C#, and the navigation is controlled by GPS.

This project is similar to ours with regards to the automation and the camera capabilities, but our project takes the idea further. The Automated Rescue Vehicle will utilize the camera mounted on it as a means to search and locate desired objects via image processing, which as stated previously, can have great benefits in search and rescue missions out at sea. While the GPS control would

likely improve our project, we've chosen to create a basic search algorithm to not dedicate too many resources to the driving pattern of the project, and instead, put those resources to the more demanding parts of the project such as the vehicle automation and the image processing.

*Figure 1: Arduino GPS Drone RC Boat*



### 2.4.1.1 A.R.V Comparison to Drone RC Boat

Overall, the figure below shows a side by side comparison comparing the GPS drone RC boat and our ARV design. It can be shown that our design provides another step for accuracy with object detection including through image processing. A display for data collection is also used in our design for multiple safety measurements and user needs

*Table 1: Arduino GPS RC Boat VS. ARV*

	<b>Arduino GPS Drone RC Boat</b>	<b>Automated Rescue Vehicle</b>
Vehicle Automation	Yes	Yes
Camera	Yes	Yes
GPS Control	Yes	No
Image Processing	No	Yes
Data Collection Tools	No	Yes

## 2.4.2 Roboat

The Roboat is a collaboration project between the Amsterdam Institute for Advanced Metropolitan Solutions (AMS Institute) and the Massachusetts Institute of Technology (MIT) that began in 2016 and is scheduled to be completed in 2021. Rather than a simple autonomous boat, the goal of the project is to make a fleet of autonomous vessels that are capable of moving people and goods through the creation of portable infrastructure, most notably bridges. As seen in the image above, the individual vessels coordinate with each other autonomously to link together to create a chain of two boats as shown below. As of now, prototypes are being tested in the canals of Amsterdam.

*Figure 2: Two Roboats linking together*

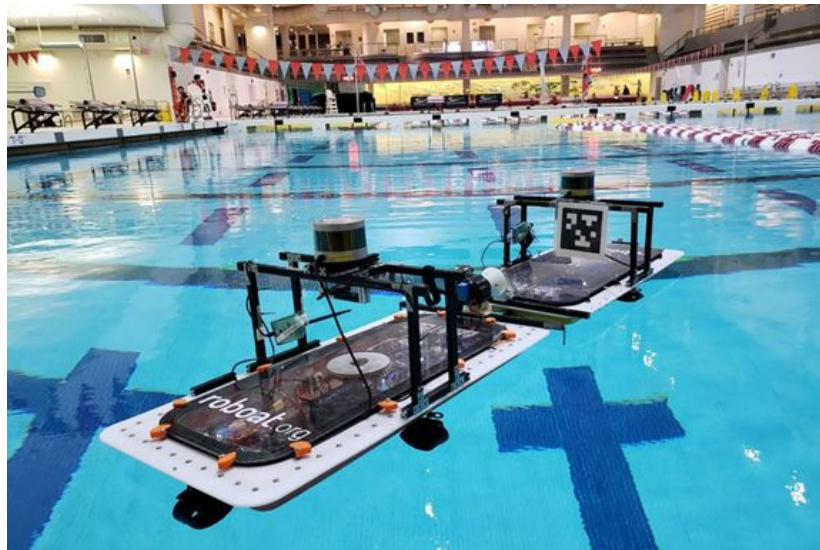

On a larger scale, several of the Roboats would all link together to create a large bridge as shown in the image below. The image below is just a sample drawing of what the technology would look on a large scale. There are also other sample images online displaying what the device would look like when transporting goods and people.

Another aspect of this related project is how the design can be linked together to form a bridge. This of course needs multiple hardware and much more cost analysis compared to our design project. It also would require a lot more time to provide a sophisticated design such as the linking bridge.



*Figure 3: Sample image of Robots linking to form a bridge*



Objectively, this project is much more intricate than the Autonomous Rescue Vehicle, and understandably so, as this is a five-year project. The Roboat takes boat autonomy to the next level, and even utilizes neural networks to realize image processing to recognize objects in the canal environment. On their official website, “roboat.org”, the Roboat applies the following techniques in its operation:

- Inertial Navigation System
- Image Processing
- Motion Planning with Obstacle Avoidance
- Predictive Trajectory Tracking
- Route Planning
- Latching
- Multi-vessel Coordination
- Environmental Monitoring

### **2.4.3 SeaCharger**

The SeaCharger is a project by Damon McMillan, Troy Arbuckle, Matt Stowell, and JT Zemp to make “the first unmanned surface vehicle (USV) to cross an ocean on solar power alone.” In other words, a solar-powered autonomous boat. While the project is currently retired, before its retirement, the SeaCharger managed to complete a voyage from California all the way to Hawaii. The SeaCharger was then set to sail for New Zealand and managed to get within 300 miles of the shore before the rudder died and the boat was unable to go any further. The SeaCharger began as a hobbyist project and is mainly built using hobby-grade/homemade components.

*Figure 4: Sea Charger sailing at sea*



For a boat made of simply hobbyist components to be designed in such a way where the vessel is able to make it within 300 miles of New Zealand's shore from California is an amazing feat. The project took 30 months to complete and overall, the project was partially a success. After the rudder had gotten damaged 300 miles from the New Zealand shore. The SeaCharger was eventually recovered and spent the next six months in the New Zealand Maritime Museum.

As what we have planned for the Automated Rescue Vehicle, the SeaCharger is capable of switching between autonomous navigation and radio control. The SeaCharger is much sturdier than what we have planned for the A.R.V. as we don't plan on designing it to traverse the ocean. We will have it navigate calm bodies of water just as a proof of concept. Also, the A.R.V. will likely not be solar-powered.

## **2.5 Requirements Specifications**

Requirements for the entire system will be split into three levels. The first will be the system operating as a whole. Level 1 will state requirements for the controller and boat operating together. The second level of requirements will be directed toward how the boat should operate. The third level of requirements specifies how the controller shall operate.

### **Level 1**

\* **Note:** Within this section of Level 1 requirements, "The System" will refer to the combination of the rescue vessel and its remote controller with data display.

- The system as a whole shall be lightweight and easily portable
  - Weight Limit: 15lbs
  - Dimensions: 18in x 8in
  - Autonomous
- The system price shall not exceed \$600
- The system shall have a battery life to sustain ample exploration.
  - Minimum Time of Operation: 15 minutes
- The system shall be rechargeable
  - Battery life shall be greater than 1 hour and provide enough power to multiple parts through regulators.
- The system shall be able to work in different environments or bodies of water, i.e, pool, lake, etc.
- The system shall be waterproof
  - IP68+ rating
- The system shall be able to withstand reasonable shock from impacts with possible obstacles (stumps, waves, etc)
- The System shall be able to receive and transfer video, depth data, values to a laptop or phone display wirelessly.
  - The data for image processing shall be processed through a raspberry pi board due to high processing capability.
  - Processed video shall be transmitted wirelessly through wifi
  - All other data from sensors shall be transmitted wirelessly and monitored by an alternate microcontroller such as the MSP430.
  - Data from sensors must be transmitted wirelessly either through wifi, bluetooth, or RF Modules
- The System shall be able to communicate and transmit data back and forth within a specific range
  - Control Range shall be greater than 20 feet
  - Depth Sensor Data Transfer: Range shall be greater than 20 feet
  - Live Camera Feed Data Transfer: Range - wireless video transfer shall be greater than 20 feet.

## Level 2

\* **Note:** Within this section of Level 2 requirements, “The System” will refer to the exploration vessel.

- The System shall be able to maintain buoyancy with the addition of analysis equipment.
- The System shall maintain aero and hydrodynamics with the addition of data recording equipment.
- The System shall be able to navigate waters with a minimum depth resolution

- The boat shall be able operate at a shallow depth at a minimum of 18mm
- The System shall be able to undergo various speeds up to without affecting efficiency.
- The object detection efficiency shall not be greatly affected by varying motor speeds.
- The System shall be a low power system with maximum operating voltage of 12V
- The motor in the System shall have a maximum power of 8000rpm
- The motor shall be driven by an 11.1V Lithium Polymer battery
  - Possible Solar Battery
- The System shall be able to maintain data transfer efficiency while moving
  - Depth readings shall have accurate measurements while the vessel is in movement.
- The power system and circuitry shall have leakage protection and be completely sealed for waterproofing.
- Any wireless communication between systems shall have a data transfer range minimum of 10 meters
- The system shall have various voltage regulators outputting a voltage range of 3.6-15V for microcontroller, depth sensor, and 3.3-5V for camera.
- The output current for voltage regulators shall not exceed max current ratings.
- The Depth sensor in the system shall be able to record depth values within the specified range of 1in - 50feet or greater
- The camera shall be able to transmit live video feed to the remote control display
- The System shall be able to identify humans and recognize with a high percentage.
  - Possible multiple object detection for secondary design
- Minimum percentage for correct identification shall be 70%
- GPS locator shall provide accurate location of boat at all times using the msp430.
  - GPS modules must be displayed to the open sky for accurate results for satellite communication.
- The system shall be able to go into recovery mode for when the battery is too low and the battery pack is switched.
  - Recovery mode shall allow ford gas location to continue and minimum operating functions of the boat to continue

## Level 3

\* **Note:** Within this section of Level 3 requirements, “The System” will refer to the controller and display aspect of the design.

- The System shall either be a laptop or iphone or any smart device compatible with wifi or bluetooth
- The System shall be portable and able to connect wirelessly
- The System display shall have a high resolution enough to stream play live video feed from the camera module.
- The System shall have a display suitable for users of all eyesight abilities
- The System shall receive control data quickly so that the boat can maintain fluid control on a body of water
- The System shall have a battery life indicator function or be monitoring the battery for low voltage and need of recharge
  - Display of GPS should be easily seen in both normal operating conditions and in recovery mode.
  - Display of the depth reading shall be easily seen in both modes
- The System shall have a warning when the vessel is approaching its shallow water below 2 feet.
- The System shall be user friendly
  - Minimal controls: power and steer
  - Automation can be turned off and manually controlled
- The system shall maintain controls of the display
- Multiple screens on the display is required for viewing both live video stream and for retrieval of data from the sensors.

## 2.5.1 Engineering Requirement Summary Table

The following table outlines 7 specific requirements and values for our main design. Its purpose is to establish a minimum of 3 demonstrable specifications of the Rescue vehicle. The highlighted requirements will be demonstrated.

Table 2: Main System Requirements with specific values

Requirement	Value
Depth Sensor Reading Threshold	± 5%
Object Detection for a person	70% assurance
GPS Location Update	<5 seconds
Regulator Output Threshold	± 3%
ARV System Runtime	>30 minutes
Communication Range	>10 meters
Cost	<\$800

## 2.6 House of Quality Matrix

The figure below outlines a house of quality matrix that provides details on the correlation between marketing and engineering requirements for our rescue vehicle. Marketing requirements such as ease of use if for the user interface. Our product should be easily implementable once it is finished and the figure below outlines how the engineering requirements satisfies that. High performance, range and versatility are all important user friendly requirements for marketing and are all correlated to the engineering specifications described below.

Figure 5: House of Quality Matrix

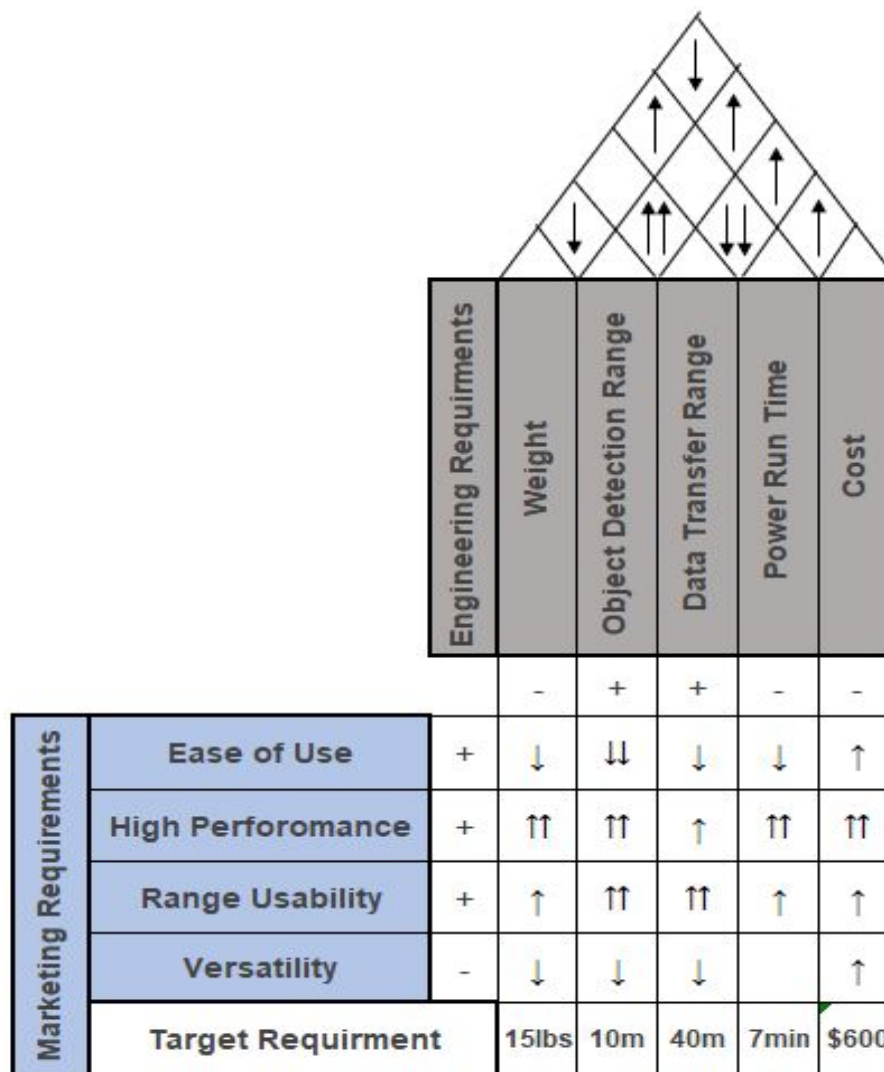

↑ = Positive Correlation  
 ↑↑ = Strong Positive Correlation  
 + = Positive Impact Requirement

↓ = Negative Correlation  
 ↓↓ = Strong Negative Correlation  
 - = Negative Impact Requirement

## 2.7 ARV Block Diagram

The Autonomous Rescue Vehicle design can be split up into two aspects. The first portion of the block is designated to the REmote and Display components and operations. The second block of the design diagram includes the rescue vehicle and all of its components and operations. The following block diagram will explain how the entire system is connected and how data travels from the rescue vehicle to the display for the user to read. The Raspberry Pi will be specifically used for image processing and the camera module will be connected directly onto the Pi board. All other sensors will be connected to the MSP430 on the PCB with a power supplied by the regulators on the PCB. Although two microcontrollers are used, data from both will be transmitted to the same display.

Figure 6. Initial System Design Block Diagram

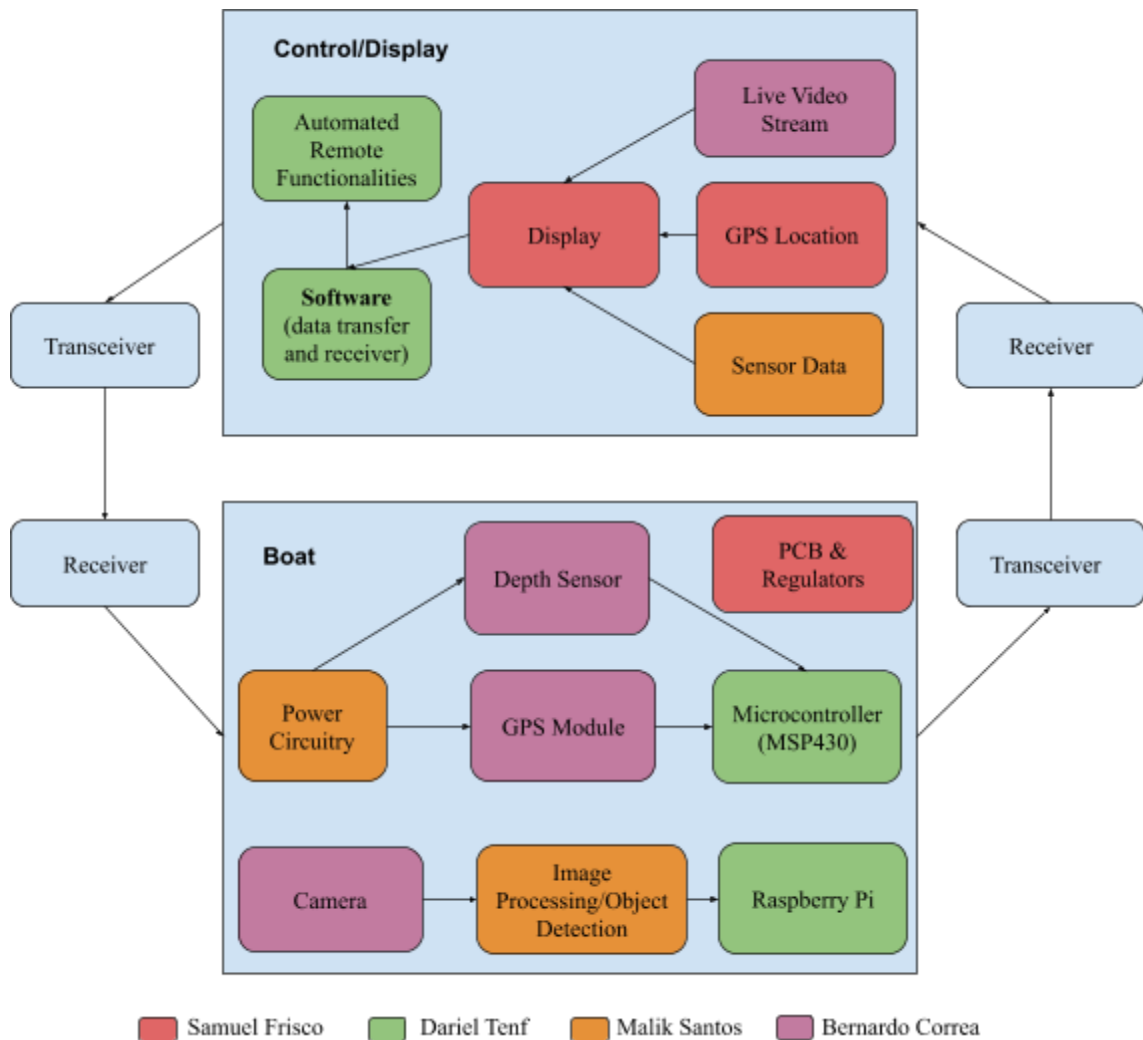

## 2.7.1 Block Status

**Power Circuitry** - Research and Purchase - Researching operating voltage ranges and circuit protection for both feature and basic operation components. Also battery material options and brushed vs brushless motors. All research is being done with the goal of a single power source.

**Research and Purchase**- Finding and tuning equipment to correct frequencies.

**PWB/Schematics** - Research, Design and Purchase- Designing schematic digitally and then ordering the result.

**Display** - Research and Purchase- Installing display inside of the remote with a shared power source.

**Depth Sensor** - Research and Purchase - Investigate different types of sensors such as sonar for depth measurements. Research quality and resolution of part.

**Camera** - Research and Purchase - Investigate different cameras based on cost, quality, resolution, and wireless transmission

**Microcontroller Programming** - Research - Finding optimal coding language to use for the software design aspect of the project.

**Remote Functionalities** - Research - Finding how to produce the software specifically required for the different features we desire for the control of the boat.



## **3.0 Research and Part Selection**

### **3.1 Relevant Technologies**

#### **3.1.1 DC-DC Converter and Voltage Regulator**

A DC-DC converter takes a DC voltage from a source (a battery in our application) in a given range and outputs a voltage in a different range. It is a broad term that can cover boost converters (step up voltage) or buck converters (step down voltage). The boost decreases current while the buck increases current. DC converters are generally more efficient in high current applications, however there is some variation in output which is the main difference between these converters and voltage regulators.

Linear voltage regulators are more complex and far more specific than DC-DC converters. They take a range of input voltage and output a fixed, accurate voltage. They are better suited for applications that require as little variation as possible in its output voltage, i.e. the input voltage for the components in use. They are more efficient in low current applications, which is what the A.R.V. system will be.

##### **3.1.1.1 Integration**

These components are essential to any DC application with varying operating voltage requirements, i.e. several small components powered from a common supply. Our voltage needs range from 3.3V - 11.1V. The components of focus for DC supply are the boat itself (motor and servo), the receiver (for control signals), and the Raspberry Pi. The Pi itself will power the camera module, depth sensing transducer, and video/depth data signal transmitter. This will put a large burden on the supply to the Pi, which needs to maintain power throughout operation and return, as sudden loss of power can corrupt the memory of the board. We will further explore (and implement) the linear voltage regulator, to ensure stable and clean output voltage to the sensitive components.

The linear regulator will allow for our main source of power to supply appropriate voltage to the boat and the video transmission system, the system being the Raspberry Pi and supporting components. We have chosen Lithium Ion Polymer as our battery technology because of its weight savings and energy efficiency, however there is a large obstacle to overcome in the use of LiPo. We must establish a safety net in the case of the cell voltages dropping below a safe value (3.0V), due to the risks reviewed in battery selection. It is in overcoming this obstacle that the Raspberry Pi backup battery will assume power supply responsibilities.

We will implement in our power system, a method of monitoring the cell voltage of the LiPo pack, and a switch to the backup battery to protect the life of the main power supply. We cannot avoid a system reset in the interim of switching power supplies, so the system will return in a recovery state. It must be considered that the battery backup itself is a LiPo battery, however the board of the backup PSU has built in monitoring and shut off when the cell voltage drops to 2.8V, so the life of the backup battery is protected as well.

### 3.1.1.2 Converter Comparisons

There are two main types of regulators called switching regulators and linear regulators. There are also step up, step down and shunt regulators, however, these usually fall under either linear or switching. There are different configurations for a switching regulator such as buck, boost, buck-boost and flyback which will be explained at the end of this section. Some advantages for linear regulators are that they provide simple circuit configurations, have few external parts, and are low noise systems. However, the disadvantages are that they have low efficiency and generate a lot of heat. The only configuration of a linear regulator is a step down converter (buck).

Figure 7: Internal and external circuit for linear regulator; Courtesy of ROHM

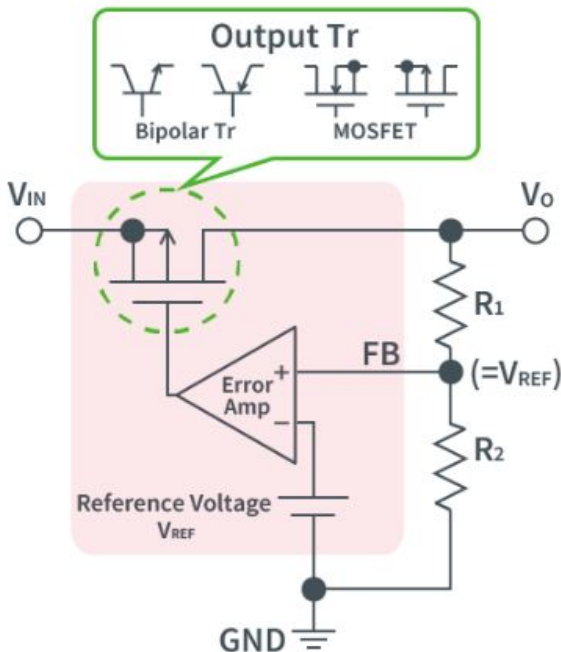

A switching regulator uses a switching element to take the voltage from the power supply and turn it into a pulsed voltage. The voltage then becomes smooth by using external capacitors and inductors. Power is run through the circuit by turning the switch ON (MOSFET), until the desired voltage level is reached. Once

this value is reached, the switching element is turned off so no power is consumed in the input. This repeated switching allows for more efficiency and less heat consumption. Switching regulators also allow for boost and for negative voltage operation. However, a disadvantage is that more external parts are required, there is increased noise, and has a complicated design.

Figure 8: Switching Regulator Circuit; Courtesy of ROHM

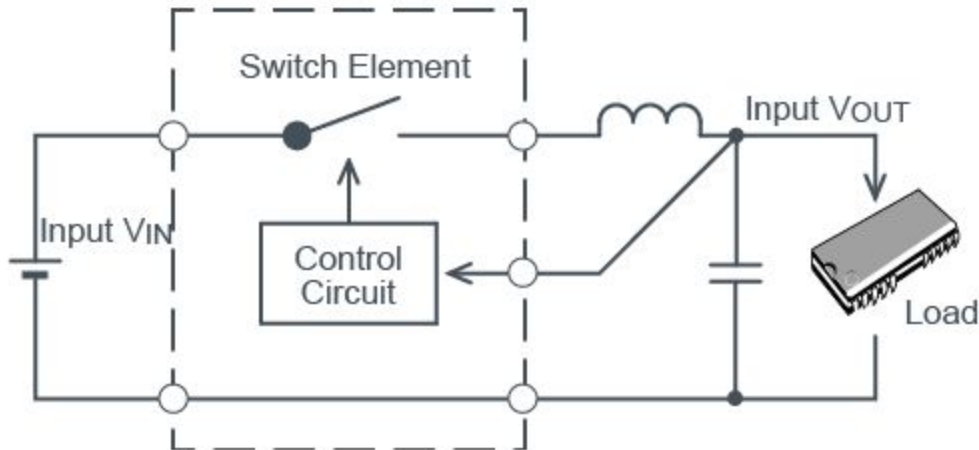

A comparison can be made between choosing a linear regulator or a switching regulator for our design project. The following table outlines specific qualities of each regulator that will help us decide on which regulator will give us the best quality performance in our system.

Table 3: DC-DC Comparison Table

Specifications	Linear Regulator	Switching Regulator
Noise	Low	High
Efficiency	Low	High
Heat Generation	High	Low
Circuit Complexity	Low	High
Operations	Buck (Step-up)	Buck, Boost, Negative

## **3.1.2 Motors**

A motor is an electrical component that converts electrical power into mechanical energy. Motors use the magnetic field of the wire and the current to create torque for the motor by rotating the rotator 180 degrees. Motors have been extremely common parts for many years especially in smaller model systems. However they have become even more prevalent and advanced with the use of them within electric cars and vehicles.

The A.R.V will be using small RC motors to propel its frame forward. These are extremely common in model boats, airplanes and cars. These specifically use a rotor to spin 180 degrees when a electric current is put through the armature. These motors have permanent magnets on the rotor and electromagnets on the stator. The electromagnets are then charged on the stator to rotate the full 360 degrees.

### **3.1.2.1 Integration**

These are obviously essential to any project of our type. Our boat needs to be propelled through the water to reach new areas to be scanned with our image processing. These motors will be mounted in the inside of our hull and connected to both our battery for power as well as our propellers. The propellers will be rotated with the motor causing the boat to be able to move. These will be powered by a 7.4 V battery and can take our system to speeds upward of 5.4 km/h. These will be our only source of propulsion and the only one we need, it should be able to travel at these constant speeds for around 2 hours straight.

The connections are simple with only two wires needed connected to the battery. These will be connected to either the battery directly or the microcontroller, regardless they will need to be connected to their appropriate positive and negative terminals. The other side of the motor will have a direct mechanical connection to the propellers at the back of the boat. The propellers are the female connection and the end of the motor the male part, this is inserted and clipped into the propeller.

### **3.1.2.2 Motor Comparisons**

There are two types of main motors that are used AC brushless motors and DC brushed motors. Each of these provide their own unique advantages. The DC brushed motor makes physical contact with the commutator. When you apply a DC voltage to the brushes it creates a transfer between them and the commutator, this causes the windings to be powered. This electrical sequence generates a magnetic field which turns the rotor and creates torque for the

system. Some of the advantages of these motors is they are very inexpensive and are easily fixable however we would prefer something that doesn't break quickly considering it will be in the hull of our boat and around other valuable components.

Figure 9: DC Brushed Motor



The AC brushless motors use induction to rotate a magnetic field in the stator to turn the rotor and the stator at the same rate. Similarly to DC motors these have permanent-magnet synchronous motors. They solely rely on the magnets built into the motors.

These motors offer some unique advantages such as their higher torque to weight ratio and increased reliability. These were the two main reasons we chose this kind. We needed the extra power without having to weigh down the boat, or cause it to tip. The reliability is just a plus for us because the unneeded worry of the possibility of our motor breaking down.

Figure 10: AC Brushless Motor

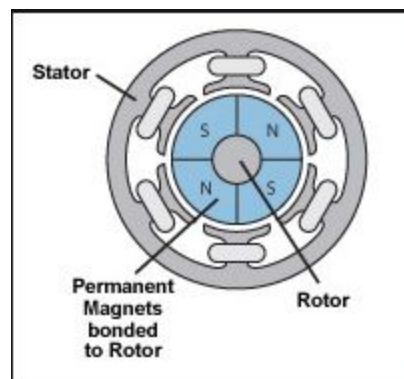

## 3.2 Software Technologies and Investigations

### 3.2.1 What is Digital Image Processing?

Digital image processing is the use of a computer to process digital images using algorithms. For the Automated Rescue Vehicle, we would need to apply digital image processing, so the camera can process images and recognize when a desired object is in its view. What's challenging about this is that the CPU can't simply record an image of a desired object and be able to consistently recognize it. The desired object could be found in unfamiliar positions and/or conditions in which despite being the desired object, the CPU won't know due to being unable to match what's on camera to what's recorded as the desired object in memory.

In order to tackle this issue, digital image processing is a practical application of the following concepts:

- Statistical Classification
  - Statistical classification is the problem of classifying a new observation into a specific sub-population of a set of sub-populations. As there are typically a finite set of sub-populations and, in the real world, it's rare that any two observations would be identical, it's even rarer that an observation falls perfectly into a subpopulation. What this means is that statistics becomes increasingly important in order to find what sub-population in the set an observation matches the most.
  - Given its nature, statistical classification is an example of pattern recognition, where new observations need to be classed based on which sub-population's patterns the new observation most accurately fits under. An algorithm responsible for implementing classification is called a classifier, and it maps input data to a subpopulation.
- Feature Extraction:
  - Sub-populations are identified by their features. Features are derived values from an initial set of measured data, which is intended to be non-redundant and informative. Feature extraction is the process of taking a set of measured data and transforming it into a reduced set of features. This set of features is known as a feature vector. In the case of the Automated Rescue Vehicle, the input data would be the images from the camera. Features need to be extracted to find if an image contains a desired object. With images, generally, features are extracted from shapes.
- Signal Processing:

- Signal processing is the science of analyzing, synthesizing, sampling, encoding, decoding, enhancing, transporting, archiving, and basically manipulating signals in some way. A signal is any physical quantity that varies with time, space, or any other independent variables. For image processing in the Automated Rescue Vehicle, we apply signal processing when we take an image (signal) and extrapolate data from it. Essentially, image processing is a subcategory of signal processing.
- Pattern Recognition:
  - Pattern recognition refers to the automated recognition of similarities and patterns within sets of data. It is the basis of statistical classification as the recognition of patterns is essential to the proper classification of a piece of data into its respective category.
  - In modern times, pattern recognition is also closely associated with machine learning as the computer needs to be able to produce more rigid boundaries between subpopulations to more accurately classify new data. It is common that pattern recognition systems are fed “training” data to be able to recognize desired patterns. This is known as supervised learning. Supervised learning is most likely the method that we will use once we properly incorporate image processing into the Automated Rescue Vehicle in order to establish pattern recognition to identify desired objects.
- 3D Projection:
  - A 3D projection is a mapping of points in a three-dimensional space onto a two-dimensional plane. Although there are several different types and methods of projection. The most relevant method of projection for image processing on the Automated Rescue Vehicle will likely be perspective projection.
  - It's unrealistic that a desired object be sought by the A.R.V. would be present on the water in the same or even similar positions as what's already been registered by the CPU. As a result, perspective projection provides a method to facilitate the CPU recognizing a desired object from different perspectives.

### **3.2.2 What is Machine Learning?**

Machine learning is a subdiscipline of artificial intelligence focused on the study of computer algorithms that automatically become more proficient through experience. This learning process allows computers to discover how to perform certain tasks without being explicitly programmed to perform said actions. This has very practical applications when attempting to have a computer perform complex tasks where it would be increasingly difficult for a human to manually create the proper algorithm to complete the tasks. The programmer instead allows the computer to develop its own algorithm by labelling desired outputs as

“valid,” which prompts the computer to more efficiently produce valid outputs. Approaches to machine learning are broadly divided into three categories.

These categories are as follows:

- Supervised Learning:
  - In supervised learning, a “teacher” feeds the computer a set of example inputs with their respective expected outputs with motive to establish a general behavior for the computer to map inputs to desired outputs.
- Unsupervised Learning:
  - Unsupervised learning is understandably opposite to supervised learning where instead of being fed inputs with their expected outputs to create a mapping, the computer is left to find its own patterns with the inputs to create a structure. This often leads the computer to find hidden patterns in the data that would have otherwise gone unseen by humans.
- Reinforcement Learning:
  - For reinforcement learning, the computer program is placed in a dynamic environment in which it is to accomplish a certain goal. The computer program’s progress towards completing said task in the given problem space is provided as feedback, and the program attempts to maximize the progress in hopes to complete the task. An example would be having a program play a game with the objective of beating it, and as it keeps playing, it gets more and more proficient at playing the game.

### **3.2.3 What is Vehicle Automation?**

Vehicle automation is the use of artificial intelligence to assist in the operation of a vehicle. For this project, we are primarily concerned with navigation autonomy, so the Automated Rescue Vehicle (A.R.V.) may traverse a body of water and independently search for a given object. There are six levels to categorize autonomy in vehicles. These levels are as follows:

- Level 0 – No Automation
- Level 1 – Driver Assistance: In specific circumstances, the vehicle can independently control either steering OR speed to provide assistance to the operator.
- Level 2 – Partial Automation: In specific circumstances, the vehicle can independently control both steering AND speed to provide assistance to the operator.
- Level 3 – Conditional Automation: The vehicle is capable of taking command of both the steering and the speed independently under normal environmental conditions with an operator’s oversight.



- Level 4 – High Automation: The vehicle is capable of completing a trip independently under normal environmental conditions without the oversight of an operator.
- Level 5 – Full Autonomy: The vehicle is capable of autonomously completing a trip in any environmental conditions presented to it.

With the information just presented, the A.R.V. would likely be classified as a level 3 autonomous vehicle (conditional automation) as the A.R.V. is to be able to traverse and search a body of water to find an object independently, but if needed, will be able to switch to human control to navigate the water.

### **3.2.4 ROS**

ROS stands for Robot Operating System. It is a flexible framework designed by Open Robotics used for writing software for robots and has a wide assortment of libraries and resources to simplify the process of devising robust behavior for robots. Throughout our research, as well as some previous experience, we've found that ROS has a lot of open-source materials for us to incorporate into the more difficult software aspects of the Automated Rescue Vehicle (A.R.V.). These materials include joystick drivers, camera drivers, image processing libraries/packages, and navigation libraries/packages. ROS' main supported libraries are C++ (roscpp) and Python (rospy).

### **3.2.5 C++**

C++ is a programming language created as an extension of the C programming language. Unlike C, C++ is object-oriented, similar to Java. Object-oriented programming is a programming paradigm centered around the idea of values in memory known as "objects." Objects include data structures, functions, methods, and variables. For class-based object-oriented languages, such as C++ and Java, an object is an instance of a class, which can be a combination of the previously mentioned pieces of data (functions, data structures, variables).

Despite C++'s similarity to Java, C++ is almost identical to C syntactically and is widely known as a superset of C. Most C code would easily compile correctly in C++, except for a few exceptions, as C++ introduces many new keywords that aren't present in standard C. If they were to be used in C code as identifiers, the C code would not compile correctly in C++. C++ is widely used and compatible with both ROS and MOOS-IvP, making it very attractive to consider using for designing the software for the Automated Rescue Vehicle.

### **3.2.6 Python**

Python is a high-level, general-purpose programming language that supports several programming paradigms. This includes procedural, object-oriented, and

functional programming. Python uses a significant amount of whitespace to encourage and emphasize code readability and assist in writing logical code that can be easily understood. Python has a very comprehensive standard library and is often considered very user-friendly to beginners due to its very organized nature. Unlike several other programming languages, blocks of code are not bounded by curly braces, rather with indentation. Also, semicolons are optional to end a line of code as newline characters provide the same functionality. Although it is incompatible with MOOS-IvP, Python is compatible with ROS, and its simplicity makes it very attractive as it can ease the learning curve of those in the group that aren't so proficient with coding.

### **3.2.7 MOOS-IvP**

MOOS-IvP stands for Mission Oriented Operating Suite – Interval Programming, which is an open-source set of C++ modules that, while it can be used for all robotic platforms, specialize in providing autonomy for marine vehicles. MOOS seems to have a lot more open-source material on autonomy that we can use for the A.R.V., but lacks any resources on the additional functionalities that must be implemented.

### **3.2.8 PID Controller**

In order for the boat to autonomously traverse a body of water, it's highly recommended, if not necessary, to implement a PID controller for the speed and the course of the boat. A PID controller, known as a proportional-integral-derivative controller, is a control loop mechanism within a control system that uses feedback to ensure that a system maintains steady-state and can quickly and efficiently return to steady-state should the system encounter any noise, which is almost guaranteed to happen in the real world. A PID controller has three separate components, each with their own responsibility in eliminating error. The three components are as follows:

- P – the P in PID stands for proportional, and this component acts somewhat as a first responder when there's an error in a control system. If an error is large, the P component of the controller will have a proportionally large control output which is constant. In most cases, the P component alone results in a constant error between the desired steady-state value and the actual output, which is why it's not used exclusively.
- I – the I in PID stands for integral. This component has a slower response than the P component and works to completely eliminate any residual error that still exists in the system over a period of time. It accomplishes this by introducing a control effect due to the cumulative value of the error over a period of time. This nullifies the P components shortcomings of leaving a constant error after its response.

- D – the D in PID stands for derivative. This component is different from the previous two components in the aspect that the D component has no bearing on the actual output of the system, rather it's a controller for the output's rate of change. With just a P component and an I component in a controller (otherwise known as a PI controller), the system can potentially exhibit oscillatory and unpredictable behavior in a noisy system. The reason for this is that the noise in the system can cause a large and sudden spike in the output of the system, which would result in an equally as sudden spike towards steady-state from the PI controller. The D component reduces the rate of change, so that these spikes don't occur so suddenly, so that the other components within the controller can take action on the system before the error becomes drastically large, and when the P and I components do take action, the system's output doesn't spike back to steady-state, rather gently drops to steady-state. This results in much less oscillatory behavior, and a much better control system.

Together, each of these components are crucial in applying accurate and optimal automatic control.

## **3.3 RC Boat**

### **3.3.1 URUAV 2011-5 Generation**

Many things were in consideration in the purchasing of our vessel. Our boat will be purchased as a pre assembled RC boat to avoid any hassle with assembly. It also needs to have a deeper hull and so that we can have room for the addition of parts. The hull needs to be waterproof so that it can hold our additional PCB, raspberry Pi and power sources. Also the length and width of the boat need to be larger than your average RC boat for balance. If you mounted our camera and sensors on some of the smaller models you could easily tip or off balance the frame causing the boat to sink.

Another consideration is speed, while we dont need this to go incredibly fast we need the initial speed to be higher than our goal. This is because we will be adding weight to the boat with our camera sensors etc, which will inevitably lower the speed of our vessel

### **3.3.2 Spartan Race Boat**

The spartan race boat has too much power going upwards of 50 miles per hour, this would cause our system to be unstable and non desirable. The battery and really the overall product is far too luxuries for our needs. The expense shows this even further costing \$125. The need to find a place for our extra electronics

as well as sensors will prove difficult because of its hull being pre sealed with no easy access points.

### 3.3.3 Fish Catching RC Boat

The fishing boat was a consideration because it has the needed speed capacity as well as the idea of carrying extra weight being already integrated in its capabilities. However the size of the boat was a little smaller than we hoped for which would bring on challenges for our extra required electronics. As well as the exterior plastic paraphilia that is used to mimic an actual sized boat would get in the way, as well as cause sealant issues inside the hull when removed. Finding the exact versatility was finally achieved in the Flytec 2011-5.

Figure 11: Flytec 2011-5



### 3.3.4 Flytec 2011-5

The Flytec 2011-5 satisfied all our needs as mentioned above. We are able to purchase this boat full functional and ready to drive eliminating the hassle of building a working RC boat for our project. As seen in the picture there are a series of screws that connect the top and bottom half of the hull, between these two sections is a rubber seal that goes around the circumference of the boat.

This creates an ease of access to the interior of our boat without having to compromise the waterproofing of our vessel. This boat's hull measures at 20 cm height and 50 cm in length, this is much larger than your typical RC boat on the market which provides the needed room for our added circuitry and sensors. All data offered by the company is recorded in the table below.

Table 4: RC Boat Comparison for Selection

Product item	Flytec 2011-5 (Selected)	The Fish Catching RC Boat	Spartan race boat
Product material	ABS Plastic & Electronic Parts	ABS Plastic & Electronic Parts	ABS Plastic & Electronic Parts
Control time	2 - 24 hours	6-8 hours	---
Charge time	10 - 12 hours	10 hours	---
Product size	50 L * 27 W * 20 H Cm	17 3/4" L x 5 1/2" W x 7" H	36 " L x 9" W x 5" H
Load capacity	1.5 kg	1.2 kg	0
Max speed	3.4 Miles/h	5 miles /h	50+ Miles/h
Product weight	2020 g	567 g	---
Control distance	500m	---	---
Battery	7.4V 5200mAh	9 V	8.4V NiMH
Controller battery	1.5 V AA x 4	1.5 V AA x 6	1.5 V AA x 4

The battery and servo card are located inside this sealed hull already and we will simply work around these in the abundant room that is provided to add our extra circuitry. The boat measures a width of 27 cm which is also much wider than the speed boat RC models you typically find for purchase, this will add for extra stability we will require once we offset the natural buoyancy of the boat with our cameras and sensors. In the scenario that we may need additional room for circuitry or if we wanted to mount a camera on the backside of the boat we could easily remove the compartments on the rear of the vessel. After removing this we could add a mount for the camera or a box for extra circuitry.

One of the more unique features of this boat is its speed, as noted in the data sheet it travels at a max speed of 5.4 km/h but this is with a load up to 1.5 kg. Because we have no intention of keeping the deployable carriers on the back of the boat this means we will still have that max speed once we attach our extra circuit boards, cameras and sensors. These add ons will weigh much less than the max load provided showing us we will still have plenty of speed for our boat after the additions.

Other notable qualities of the product is the astounding range it has for its connections and communications having a 500 m range. It also has a fairly long battery life at 2 hours of constant use, while it can still be fully charged overnight.

## **3.4 Microcontrollers**

### ***Component Selection***

#### **3.4.1 Overview**

A microcontroller is a small computer system on a single integrated circuit (IC) chip, that performs a task. They are also known as MCUs. They contain one or more CPUs, memory, and programmable in/output peripherals, and are essential to any project that will take an action when given commands of varying forms. The microcontroller will be the heart of our project design and function.

One of its central functions will be to facilitate communication between the remote controller and the boat. This will include commands for movement, information relay from sensors, and data transmission. The goals of object detection and video transmission significantly increase the performance requirements of the microcontroller for the A.R.V. system. We will consider three MCU platforms: the Texas Instruments MSP430, the Raspberry Pi, and the STM32F4 series based on the ARM Cortex M4 chip.

#### **3.4.2 Texas Instruments MSP430 Series**

The first MCU in consideration is the TI MSP430. It is in fact a large family of microcontrollers that vary in many ways. The first identifier in the part number distinguishes memory types: **F** - flash (most popular), **C** - masked ROM, **FR** - FRAM, **G** - flash value line, and **L** - RAM only. Additional letters indicate special functionalities. The next digits indicate the generation and model within the generation, followed by digits indicating the amount of memory the specific model has.

There are also suffixes for various options from expanded temperature ranges to automotive qualifications. In short, the MSP430 family tree has many branches. It is a familiar and very capable platform - built around a 16-bit CPU with low power consumption as a core function. Its operating voltage is between 1.8 and 3.6 Volts, with memory capacities of up to 512KB of flash memory and 66 KB of Random Access Memory (RAM).

The MSP430 also integrates Ferroelectric RAM (FRAM). This "...is a memory technology that combines the non-volatility of flash and the flexibility and low power of S[static]RAM." There are six low power modes that can disable undesired clocks and even the CPU, boasting wake up times under 1 microsecond, and current draw capabilities under 1 microamp. These features could be useful as the A.R.V. lies in wait for a disaster to respond to.

*Table 5: MSP430 Data*

<b>Specification</b>	<b>TI MSP430 Family</b>
Input Voltage	1.8V - 3.6V
Power Consumption	230 $\mu$ A at 1MHz, 2.2V (Five Power Saving Modes)
Clock Frequency	16 MHz (up to 25MHz)
Memory	0.5KB - 512KB
RAM	0.125KB - 66KB
I/O Pins	4 - 100
Architecture	16-bit RISC
Dimensions	1.75 x 1.85 inches
Cost	\$25.00

Figure 12: MSP430 Microcontroller



### 3.4.3 Raspberry Pi

The next microcontroller in consideration is the Raspberry Pi, although it is much closer to a computer than a microcontroller. The Pi was created with the goal of educating young people in the basics of programming. It is quite powerful, stretching the actual definition of a microcontroller. It is capable of plugging directly to a monitor or TV and runs as a Linux computer, however it also has general purpose in/output (GPIO) pins that allow for the control of external components.

The first Pi model had a single core 700 Mhz CPU and 256 MB of RAM. The latest model, the Pi 4, is available with a quad-core, 64 bit 1.5 Ghz CPU and up to 8 GB of RAM. Standard features of the Pi not found in most microcontrollers are a GPU, HDMI, multiple USB ports (2.0 and 3.0), Wi-Fi, and high RAM.

Raspberry Pi takes a step forward from the MSP430 because it has been implemented in many machine learning applications, which is necessary for object detection (a core function of this project). While the Raspberry Pi boasts the ability to run operating systems and even media, the MSP430 takes a lead in hardware control applications, as well as significant advantage in power consumption. The Raspberry Pi 4 averages 2.85 Watts when idle, which could quickly drain a small battery that an RC boat could accommodate. This is a huge consideration for this project, and will call for an independent power supply for the board.

Despite these concerns, the capabilities of the Pi are attractive for the considerable software requirements of a project based on machine learning, image processing, and object detection. The Pi also has a vast array of proprietary accessories that will build towards the goals of the A.R.V. project.



Integrating these components will be far easier than acclimating foreign parts to the Pi environment.

*Figure 13: Raspberry Pi 4 Microcontroller*

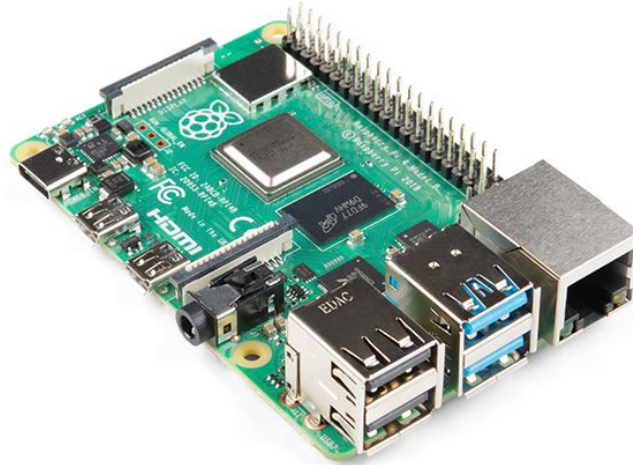

### **3.4.3.1 Connections**

The Raspberry Pi 4 Model B has a 40 pin GPIO header. There are 28 BCM2711 GPIOs available and are also backwards compatible to previous Pi boards. BCM2711 is a designation for the Broadcom chip used in the Pi 4 Model B.

### **3.4.3.2 Power Options**

The Raspberry Pi has three main power supply options. The first is 5V DC via the USB-C connector. The next option is 5V DC via the GPIO header. The final option separates the Pi from the other boards and is Power Over Ethernet (POE) ability. POE allows for power to be provided and data transmitted via a single cable.

### **3.4.3.3 Display Options**

There are multiple display ports on the Pi board. There is not a single standard HDMI port, but two micro HDMI ports. This allows the board to support dual monitors out of the box.

The table below illustrates all of the raspberry pi 4 features and parameters

Table 6: Raspberry Pi 4 Data

Specification	Raspberry Pi 4
Input Voltage	5.1V via USB-C
Power Consumption	3.4 Watts (Idle)
Clock Frequency	1.5 GHz
RAM	2GB - 4GB
I/O Pins	40
Architecture	64-bit
Dimensions	2.2 x 3.35 inches
Weight	1.5 ounces
Cost	1GB - \$30.00 2GB - \$35.00 4GB - \$55.00

### 3.4.4 STM32 Series

The final microcontroller in consideration is the STM32 family of 32 bit microcontrollers, which implement the ARM Cortex-M4 processor. Flagship features of these boards are digital signal processing, in addition to low power/low voltage operation. The Cortex M4 is an extremely fast chip in the world of microcontrollers.

The STM32 is capable of 120 Mhz clock speeds, up to 2 MB of flash memory and 640 Kbytes of SRAM. Let's take a deeper look into the memory features. The flash memory on the STM32 is split into two banks. This allows for reading from one bank while writing to the other.

Figure 14: STM32 Series Microcontroller

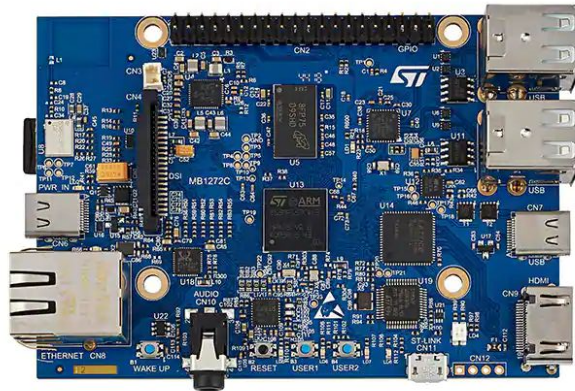

The STM32F469 model includes 384 KB of RAM with 64KB of this being designated as Core Coupled Memory (CCM). This memory is placed in very close proximity of the CPU to allow for even faster access times. Considering the requirements of the A.R.V. the STM32 shines among the three MCUs in consideration. The 32 bit data bus puts that of the 16 bit MSP430 to shame. However, there is little support for this line of MCUs, and fewer resources (opposed to the Pi) that expand on its practical capabilities. It is highly capable in partnering with Tensorflow, a potential code library that will be researched later in the report.

Table 7: STM32 Data

Specification	STM32
Input Voltage	3.3V
Power Consumption	-----
Clock Frequency	84 MHz -180 MHz
Memory	128KB - 2056KB
RAM	32KB - 384KB
I/O Pins	114
Architecture	32 Bit
Dimensions	3.27 x 2.26 inches
Weight	----
Cost	\$69.00

### 3.4.5 Microcontroller Integration

The Raspberry Pi 4 will handle the image capture and processing requirements of the A.R.V. system. We will implement the MSP430 platform on our PCB design to handle the control of the boat and the voltage regulation requirements. This approach will allow the power of the Pi to tackle the heavy requirements of image processing and object detection, as well as the transmission to the control and receiver module. The MSP430 platform is well suited for simple control commands and voltage regulation, and will allow us to integrate it to the custom design of the project. The Pi will power and communicate with the camera module. The MSP430 implementation will also monitor the voltage level of the main power supply, which will be a multicell Lithium Ion Polymer (LiPo) battery, typically found in RC vehicles where weight is a key factor. Before exceeding (in the negative direction) the minimum voltage of the main PSU, it will switch to the backup power supply and enter recovery mode. This will ensure that the system is not overdischarging the main supply and harming the components. We will further explore the power system and battery options. The below table summarizes the comparison between the MSP430, Raspberry Pi 4, and STM32 microcontrollers.

Table 8: Microcontroller Comparison

Specification	TI MSP430 (Sensor Use)	Raspberry Pi 4 (Image Processing)	STM32
Operating Voltage	1.8-3.6V	5.1V	3.3V
Current Consumption	12.5mA	640mA	117mA
Chip		Cortex A-72 ARMv8	ARM Cortex M4
Clock Frequency		1.5 Ghz	84 -180 MHz
Memory	0.5-512 KB	SD card/external	128KB - 2056KB
RAM	0.125-66KB	2-8GB	32KB - 384KB
I/O Pins	4-100	40	114
Architecture	16-bit	64-bit	32-bit
Dimensions	1.75x1.85 in	2.2x3.35 in	3.27x2.26 in
Weight	0.7 oz	1.5 oz	----
Cost	\$25	1GB - \$30.00 2GB - \$35.00 4GB - \$55.00	\$69.00

## 3.5 Depth Sensor

### 3.5.1 Goal

To measure and record the distance in meters from the bottom of the hull to the bottom of the body of water. This information will then be transmitted to the display.

### 3.5.2 Technology

Depth finding technology was first used in 1915 during world war 1. This invention at the time was used to detect submarines underwater by sending a strong acoustic pulse. This pulse is sent by a transceiver in intensity measured in decibels (dB). This is the dominant unit in all underwater acoustics. These sound waves are pulsed down at two intensity ratios of Distance 1 and Distance 2, using decibels as the unit you would be utilizing the logarithmic base 10 and expressing the ratio as  $10 \log \text{Distance 1/Distance 2 dB}$ . This pulse is sent from the transceiver to the object taking into account transmission loss caused by attenuation and sound spreading. This acoustic pulse then reflects off the object and once again taking into account transmission losses, the signal is then collected by a receiver and its values calculated. Using the general globally accepted reference intensity of one micro pascal you are able to express absolute intensities.  $\text{Decibels of Change} = 20 \times \log(\text{distance 1/distance 2})$  will then give you the distance.

*Figure 15 & 16: Sonar technology 1942 - 2020*



These technologies have continued to improve and we have seen these technologies shrink from bulky large submarine systems to miniature hand held ultrasonic range finders. We will be using a smaller transducer for our particular project, however this is proof of concept for what could be a larger scale. Range finders now can reach past 1000 yards in length, so with a larger budget or frame

work this could be implemented easily into a realistic full rescue design project using this particular technology.

### 3.5.3 SM111 Transducer

The sensors employed for our project will be a piezo ceramic disc bought and manufactured by STEMiNC. We chose this for multiple reasons, firstly the size was very attractive. The disc registers at 6.35mm X 0.7mm making it a logical and ample choice

*Figure 17: SM111 Transducer*

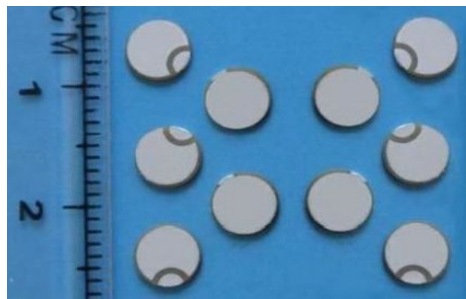

for this particular project because of its smaller nature. It also has the need to connect to a small motorized RC boat. The sensors will be connected to a frame so that we will be able to mount the transducers securely facing downward toward the bottom of the water's surface.

The transducer will be duplexed for our specific purpose. Meaning it will receive the signal from our oscillator and the amplitude from our power supply and send this acoustic pulse toward the bottom of the water. The pulse will reflect and then return and the same transducer will receive the signal and relay the information back to the microcontroller.

Duplexing is a very common procedure in antennas, transducers ect. It allows the system to send a pulse signal switch off and receive the reflected signal then switch on and send another over and over again all within milliseconds if eachother. This can be done without too much work and it reduces the need to have a separate antenna to receive all the information which would both add to costs and the overall weight of our project.

Each specific transducer will have its own data table and needs for optimal efficiency. Two of the largest of these is the power supply and oscillator of our system that will be connected to the sensor. Each sensor will have a resonance frequency, this is the frequency at which it will perform its best. While it still may work at different frequencies that are close to it, you will have your best results

the closer you are. We also need to be able to power the and supply the pulse power needed for the amplitude of the signal.

*Table 9: Data Sheet for the SM111*

Piezo Material:	SM111
Part Number:	SMD10T3R111
Dimensions:	10mm diameter x 3mm thickness
Resonant frequency fr:	215 KHz±5 KHz
Electromechanical coupling coefficient Kp:	≥60%
Resonant impedance Zm:	≤9 Ω
Static capacitance Cs:	310pF±15%@1kHz
Test Condition	23±3 °C 40~70% R.H.
fr, Zm, Kp =>	Radial mode vibration
Cs =>	LCR meter at 1KHz 1Vrms

Piezoelectric elements work under the basic principle that when you apply a current to them they will bend and flex causing vibrations, these vibrations if applied with an oscillating signal will cause the element to vibrate at your resonance frequency sending the needed transmission.

The velocity of the wave length can be described by this equation, where v is the velocity of the wave length, lambda is the distance of the wave length and f is the resonance frequency. As seen below the multiplication of the distance of the wave and resonance frequency give you the velocity of the wave.

$$v = \lambda f$$

The resonance frequency of our sensor which is 215 KHz is non negotiable because the part has one required resonance frequency. However we can choose the velocity that we want by choosing the distance of the wave. Because the frequency can be looked at as a constant we can then change the velocity by altering the distance of the wave through our oscilloscope device that we will design.

*Table 10: Data Sheet for the Piezoelectric Material*

<b>Electromechanical coupling coefficient</b>	<b>Unit</b>	<b>Symbol</b>	<b>SM111</b>
N/A	N/A	$K_p$	0.58
N/A	N/A	$K_t$	0.45
N/A	N/A	$K_{31}$	0.34
Frequency constant	Hz • m	$N_p$	2200
N/A	Hz • m	$N_t$	2070
N/A	Hz • m	$N_{31}$	1680
Piezoelectric constant	$\times 10^{-12} \text{m/v}$	$d_{33}$	320
N/A	$\times 10^{-12} \text{m/v}$	$d_{31}$	-140
N/A	$\times 10^{-3} \text{Vm/n}$	$g_{33}$	25
N/A	$\times 10^{-3} \text{Vm/n}$	$g_{31}$	-11.0
Elastic Constant	$\times 10^{10} \text{N/m}^2$	$Y_{33}$	7.3
N/A	$\times 10^{10} \text{N/m}^2$	$Y_{11}$	8.6
Mechanical Quality Factor	N/A	$Q_m$	1800
Dielectric Constant	1KHz	$\epsilon T_{33/e 0}$	1400
Dissipation Factor	1KHz	$\tan \delta$	0.4
Curie Temperature	$^{\circ}\text{C}$	$T_c$	320
Density	$\text{g/cm}^3$	$\rho$	7.9



## 3.5.4 Depth Sensor Comparisons

### 3.5.4.1 SM111 Piezo Transducer

The SM111 is a piezoelectric material that when a current is sent through it bends and flexes causing a vibration that when matched with an oscillation produces a signal that can be sent and also received from the same device. The SM111 has more than enough distance capability for our project, the max distance is dependent on our power source design however research shows achieving up to 15 ft is very simple which is more than enough distance for our needs. Its small compact size makes it ideal for our boat as well as to waterproof it.

It uses acoustics to read the distance which is a feature we were looking for and is easily compatible with our desired microcontroller. The piezo offers a touch of simplicity in that we have to do the connections manually, program the device, power it and provide it with an oscillator for its frequency. This was an attractive feature for us since we wanted to build some of these components to gain a true deeper understanding of the engineering involved. The price of the equipment is also the cheapest out of our options making this the most desired of the group.

*Table 11: Data table for SM111 Comparison*

Parameters/Features	Parameter Values
Distance max	256 cm
Distance Min	2 cm
Used Before	No
Size	10mm diameter x 3mm thickness
Measurement technology	Acoustic / Sonar
Capable of underwater usage	Yes
Price	\$9.95
Compatible with TI Microcontroller	Yes

### 3.5.4.2 PARALLAX 28015 - Sensor Board, PING, Ultrasonic Distance Sensor

The PARALLAX 28015 is your basic ultrasonic range finder for any of your small microcontroller projects. The distance was a bit shorter than we were looking for maxing out at around 9 ft. This device also used acoustics which was what we were looking for and our group has experience using these before in previous projects. Its connections to a raspberry Pi are simple because of its 3 pin header. However the option is more expensive than its competitors costing \$29.99 for just one, but the biggest con to this equipment is its inability to waterproof it in our current system.

Although it is larger and has a direct connection to our microcontroller via the 3 pin header, it would be impossible to mount on the bottom of our boat with some sort of encapsulation to keep it dry. While a viable option for dry conditions it didn't have the versatility of placement we needed.

Table 12: Data table for PARALLAX 28015 Comparison

<b>PARALLAX 28015</b>	<b>Parameter Values</b>
Distance max	3 m
Distance Min	2 cm
Used Before	Yes
Size	22 mm H x 46 mm W x 16 mm D
Measurement technology	Acoustic / Sonar
Capable of underwater usage	No
Price	\$29.99
Compatible with TI Microcontroler	Yes

### 3.5.4.3 Sharp GP2Y0A21YK0F IR Range Sensor

The GP2Y0A21YK0F IR range finder is the only other option we looked at that isn't an acoustic application, this range finder uses infrared to measure the distance. The infrared range finders calculate the distance from something using triangulation. Triangulation works by sending a beam of infrared and detecting the reflected beam's angle, with the knowledge of the angle of the reflected beam the distance can be found. This range finder has a CCD (charge coupled device) which computes and corresponding value and sends this information to your microcontroller.

The GP2Y0A21YK0F IR range finder has a max distance of only 80 cm, this is expected because generally infrared technology has a very precise measurement but is never used to measure very far. The size is favorable to our project as well as the price is only \$9.95 which is as low as the piezoelectric however, we've never used this technology before so learning curve would be high, the ability to waterproof the system mounted under our boat while it might be possible it would prove difficult as well as the limited measuring range would be an issue for what we wanted to do.

*Table 13: Data table for GP2Y0A21YK0F IR Sensor*

<b>Distance max</b>	<b>80 cm</b>
Distance Min	10 cm
Used Before	No
Size	4 cm L x 1.5 cm TH x 1 cm W
Measurement technology	Infrared
Capable of underwater usage	Yes
Price	\$9.95
Compatible with TI Microcontroller	Yes

### 3.5.4.4 Depth Sensor Comparison Summary

As discussed above the reasoning behind our choice for the SM111 was the versatility in distance it can ping, its very small size over its competitors. It fits the technology we intended using acoustics, the cheapest of the 3 as well as having easy compatibility both with a raspberry pie or PCB. It is also a very basic component allowing us to integrate the sensor how we please as well as easily waterproof the system. Because of the boat's seal it allows the boat to be opened and resealed with ease.

Table 14: Comparison and Selection of Depth Sensor

	<b>Sharp GP2Y0A21YK0F IR</b>	<b>PARALLAX 28015</b>	<b>SM111 (Selected for our design)</b>
Distance max	80 cm	3 m	256 cm
Distance Min	10 cm	2 cm	2 cm
Used Before	No	Yes	No
Size	4 cm L x 1.5 cm TH x 1 cm W	22 mm H x 46 mm W x 16 mm D	10mm diameter x 3mm thickness
Measurement technology	Infrared	Acoustic / Sonar	Acoustic / Sonar
Capable of underwater usage	Yes	No	Yes
Price	\$9.95	\$29.99	\$9.95
Compatible with TI Microcontroler	Yes	Yes	Yes

### 3.5.5 Depth Sensor Waterproofing

One of the bigger issues we had with our harmonic sensor is that it needs to be mounted on the bottom of the boat. To do this we were not able to use certain traditional TI ultrasonic range finders that we have used before in our education. It became clear we needed a smaller sensor that we could encapsulate in a material to keep it from getting wet, however this provided more issues. If we encapsulate our SM111 (see section 1.2) the harmonics would have to go

through two different impedance and densities. This would disrupt the signal and create reflections in the signal. Reflections in a signal is when along whatever medium you are in part of the power of the signal is reflected back toward the transmitter thus not traveling all the way to the point it is meant to bounce off of before returning. This creates error in the reading and less accuracy for our system. To avoid this scenario you want you medium or load impedance to be the same as your transmitter and receiver impedance. This creates continuity along the entirety of the system keeping the results tight and accurate. For our specific system the load impedance is the water that we are sending the signal through and the receiver impedance is our transducers encapsulation.

Acoustic impedance is the density of a medium multiplied by the velocity of the wave moving through that medium.

$$\text{Density (kg/m}^3\text{)} \times \text{Velocity(V/s)} = \text{Acoustic Impedance (kg/m}^2\text{×s)}$$

Finding a material that matched the acoustic impedance that could be used to waterproof the transducer was required. The specific gravity or density of this product is 1 the same as waters. This allows us to seal the transducer in this poxy while not disturbing the sound wave with reflections. VytaFlex is a two part liquid epoxy sold in the north Orlando area by Smooth-ON. We will be able to solder our connections to our transceiver then submerge it into the liquid epoxy, the epoxy will then solidify into a solid rubberish consinsty so that we can mount and seal this to the bottom of our boat pointing down toward the floor of our body of water

*Table 15: VytaFlex 20 Technical Overview*

<b>A:B Mix Ratio by Volume</b>	<b>1:1 pbv</b>
A:B Mix Ratio by Weight	1:1 pbw
Mixed Viscosity	1,000 cps
Specific Gravity (Density)	1.00
Specific Volume	27.7
Color	Clear Amber
Shore A Hardness	20A
Tensile Strength	200psi
100% Modulus	50

## 3.6 Camera

The main functionality of the rescue vehicle or ARV, is to be able to process live video for object detection. In order to properly select a viable camera for this system, many parameters must be chosen to ultimately decide what camera should be used. The most important parameter under consideration is video resolution. This is important for object detection as lower resolution can decrease the efficiency of detecting the correct object.

Connector and transmission types from the camera to the microcontroller is also important. Transmitting video from a transceiver to a receiver (from a camera to the Raspberry Pi) or using a wired connection are also under consideration. Other parameters include but are not limited to compatibility and level of difficulties for connection to the Raspberry Pi microcontroller and board, weight, input voltage, frequency and power.

### 3.6.1 Camera Options

#### 3.6.1.1 Eachine TX06 FPV Camera

The first camera option under consideration is a small FPV camera that is typically used on drones for live video capture. Using an FPV camera would require a transceiver and receiver for transmitting the video over radio frequency channel. Antennas will also be required for purchasing.

##### Pros:

There are several pros for choosing this product. It is very light weight and has low power transmitting at 25mW. The product already comes with a transceiver at 5.8GHz with 6 bands and 48 channels. Hence, there would be no need for ordering separate parts for transmitting the video. Input voltage has a reasonable range of 3.3V - 5.5V so an additional regulator is most likely not required for operating the camera/transceiver. This product is already low in cost and with the additional transceiver and antenna features, this choice would help in cost reduction.

##### Cons:

The camera has a moderate resolution of 700TVL or 700p. This could be a possible problem for object detection during image processing due to low quality video. The product may require a battery pack or another voltage regulator needed for turn on. Even if we already have a voltage regulator that provides sufficient voltage, we would require an additional signal line for operation.

Specifications and features can be seen in the table below

Table 16: Eachine TX06 FPV Camera Specifications and Features

Feature/Specification	Eachine TX06
Operating Voltage	3.3V - 5.5V
Resolution	700p/700TVL
Weight	2.8g
Transmitting Frequency	5.8GHz 6 bands, 48 Channels
Power/Current Rating	25mW/280A (Typical)
Cost	\$16.05

### 3.6.1.2 Raspberry Pi Camera Module v2

This camera option has perfect compatibility with all Raspberry Pi boards and also uses a wired connection to the Raspberry Pi. Using this module is widely preferred when transmitting video to a raspberry pi as it can easily be used in OpenCV based applications. The camera can capture high-definition video and still images and uses a wired flex cable to transmit data to the microcontroller. The cable is also included in the price of the module.

#### Pros:

This camera offers very good camera resolution at a maximum of 1080p or 1080TVL. This high-definition video capability is perfect for object detection capabilities which can help maximize efficiency ratings for detection of the correct object. The module is compatible with Raspberry Pi and extremely easy to install. It is widely used in OpenCV based applications for image processing and is lightweight.

#### Cons:

The module is more expensive than the Eachine TX06 FPV Camera and uses a wired flex cable for transmitting video to the microcontroller. Hence, parts such as the transceiver, receiver and antenna could be needed for sending video to a display since they don't come with the product. The wired connection and short flex cable that connects to the board could pose problems with waterproofing as

it will be difficult to keep all the wiring away from water. It will also pose problems with camera placement on the boat because the flex cable limits the camera's distance to the Raspberry Pi.

Specifications and features can be seen in the table below:

*Table 17: Raspberry Pi Camera Module v2 Specifications and Features*

<b>Feature/Specification</b>	<b>Camera Module v2</b>
Operating Voltage	Regulated by Raspberry Pi Board
Resolution	1080p/1080TVL (high-definition)
Pixel	8 megapixel 3280 x 2464
Weight	3g
Data Transmission	Wired
Connector Type	CSI/Flex Cable
Power/Current Rating	Regulated by Raspberry Pi Board
Cost	\$29.95

*Figure 18: Camera Module and Raspberry Pi Board flex cable*

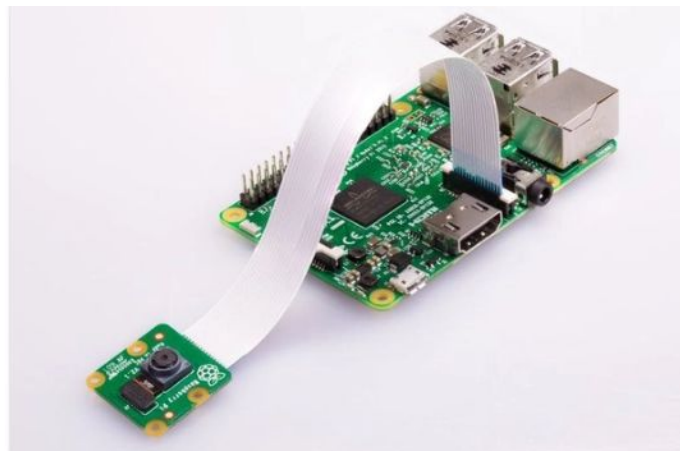



### **3.6.1.3 FPV Foxeer Razer Micro Camera**

The Foxeer micro camera provides high definition capabilities at a maximum of 1200TVL. One benefit from the camera that all other options do not have is that it has a day and night mode switch. This will provide beneficial aspects to our design as the rescue vehicle can be used at night rather than during the day. It has very low latency and is compatible with PAL and NTSC. The camera only has 4.5 grams which provides us with easy mounting capabilities to the boat.

The camera is operable from 4.5V to 25V which can be beneficial for us since we are using a LiPo battery that constantly needs to be recharged. Hence the camera can continue to work at low power conditions. One drawback of the Foxeer camera is the vertical length of the camera lens. This can cause problems during the build of the rescue vehicle as we need to provide a waterproof system. Hence, the waterproof casing would have to be large enough to accommodate for the extra camera length.

### **3.6.2 Camera Comparison Summary**

The final choice for our camera option is the Raspberry Pi Camera Module v2. This option showed multiple benefits compared to the mini FPV Camera. The resolution of the Pi module is high-definition and hence gives the benefit for a higher efficiency at object detection. The rescue vehicle will be able to detect a person in the water with more accuracy.

Although the cost is high and the camera must be connected to the Pi board by a flex cable, the positives far outway the negatives. The flex cable should not pose a problem as both the board and the camera can be waterproof through a plastic casing. The waterproof casing will be explained in a later section.

Table 18: Camera Comparison for Selection

Specifications	Camera Module v2 (Selected)	Eachine TX06	Foxeer Razer Micro Camera
Operating Voltage	Regulated by Raspberry Pi Board	3.3V - 5.5V	4.5V - 25V
Max Resolution	1080p/1080TVL (high-definition)	700p/700TVL	1200TVL
Night Mode	No	No	Yes
Weight	3g	2.8g	4.5g
Wireless Compatibility	Yes	Yes	Yes
Power/Current Rating	Regulated by Raspberry Pi Board	25mW/280A (Typical)	30mA/250A (typical)
Cost	\$29.95	\$16.05	\$24.99

### 3.6.3 Waterproof Casing for Camera Module

The water proof casing is specifically built for the raspberry pi camera and is another reason why this camera module was chosen. The casing is cheap and provides an easy way for mounting the camera on the rescue vehicle. The flex cable is easily connected through the casing as is shown in the figure below. The cost for the waterproof casing is \$2.95 and is sold by a third party Adafruit.

Figure 19: Waterproof casing for camera module



## **3.7 GPS**

### **3.7.1 Overview**

The core function of the A.R.V. system is taking rescue teams to the location of a maritime disaster, and hopefully its survivors. In an incomprehensibly large landscape such as the ocean, there is an irrefutable need for GPS tracking. This will provide a constant reference point for the controller, relative to what the camera is detecting. GPS will also play a major role in the recovery mode of the A.R.V. When main power is lost, the switch to backup power will cause a reset due to the no power interim. The system will return running off of backup power, sending an SOS signal to the operator screen as well as intermittent GPS signals, to allow for location and recovery of the A.R.V itself, in the case it runs out of power to conduct rescue activity. The GPS tracker will need to have a minimum range equal to the control range of the A.R.V, and ideally exceed it in the case control power is lost and it begins to drift. As with all supporting components - size, cost, weight, and waterproof options will be of utmost importance.

### **3.7.2 Neo 6m GPS Module**

The Neo 6m GPS module, is a global positioning system device that is very cost-effective and contains a high performance module along with a ceramic antenna. This module is very easily integratable with any microcontroller and contains an on-board memory chip along with a backup battery for extended usage. This backup battery is perfect because our system goal is to be able to have usage for extended hours. Usually, gps modules have poor quality while using it for indoor systems. However, the Neo 6m has high sensitivity performance while indoors meaning we can use this module while it is being covered in the boat haul for waterproofing conditions.

The module has an input voltage range from 3.3V to 5V. This is a perfect range as we can establish a single voltage regulator for multiple sensors that have a similar voltage range. The module also contains a configurable UART interface, perfect for communication with any microcontroller and easily programmed to constantly send location data of our rescue vehicle. The baud rate by default of the module is 9600 and has a patch style antenna. Patch style antennas are flat and connected to metal plate backing. For optimal performance of this module we will have to have open sky access which is an easy integration for our design.

### **3.7.3 Pharos GPS 360**

The Pharos GPS is a low power version of GPS modules that only needs 3V for power start up and has very good accuracy compared with the very little power it needs. It is capable of a position accuracy of 33 feet and velocity of 0.33 feet per second. Like any other GPS module, updated position information is consistently sent every second and can be read by any microcontroller through micro usb to usb connection. This connection type will not satisfy our design requirements because we will not be including a usb connect in the PCB design. However, this GPS module is still necessary to take note of in case of failures during testing for other GPS modules.

The receiver for this module is a 12-channel; module and also contains a built-in antenna like the Neo 6m. It also has bluetooth interface capabilities for data communication. The device is extremely light weight and will not affect any specifications for weight requirements for the system. This model will be compared with the NEO 6m for easy integration with the microcontroller of choice. Even if this is not chosen it has potential for being a backup in case of any problems.

### **3.7.4 Particle Boron LTE and Adafruit Featherwing**

The Boron LTE device is a quality low energy and LTE cellular module. It is capable of many network enable projects and can be an extreme efficiency upgrade for our system design. However, the cost is extremely high with a price at \$59.99. The module can act as a standalone cellular endpoint or LTE gateway for mesh networks. It has USB support and contains large RAM capacity.

Although all of these uses of this module seems great, it is unnecessary to have all these unused capabilities in our vehicle. The cost is too high for something that we only need GPS location. LTE connectivity is unnecessary and will affect our budget requirement. This module is a useful backup because it has the potential to have a connection to the entire group of local endpoints to Wifi. This will be necessary if the data transfer through radio or the TI wireless development tool becomes impossible.

### **3.7.5 GPS Comparison Summary**

A GPS requirement for our system is extremely important and needs to be continuously working. Without the device, real world cases for rescuing will not be possible because we will not know the device's location when someone has been found. Hence our decision is based on parameters that will prove a quality device and one that will meet all system requirements that was discussed in chapter 2. The summary table below fully outlines important comparisons between the 3

GPS modules. The column that is highlighted is the selected component that will be used for the autonomous rescue vehicle.

Table 19: GPS Module Comparison and Selection

<b>Specifications</b>	<b>NEO 6m Module (selected)</b>	<b>Pharos 360 Module</b>	<b>Particle Boron LTE</b>
Operating Voltage	2.7V - 3.6V	3V	3.7V
UART Interface	Yes	Yes	Yes
Receiver	50 Channel	12 Channel	-
Wireless	No	No	Yes
Data Transfer Rate	1 Hz	1 Hz	-
Location Start-Up Time	27 Seconds	60 seconds	<1 second
Cost	\$21.95	\$18.50	\$59.99

## 3.8 Boat Battery

### 3.8.1 Technologies

The primary options for RC vehicle batteries are Nickel-Metal Hydride (NiMH) and Lithium Ion Polymer (LiPo) batteries. NiMH is the older of the two and was extensively researched in the 1970s, while LiPo technology was heavily explored in the 1980s. Below is a comparison of the essential data points for the two technologies.

Table 20: Comparison Between Battery Types

	<b>Nickel-Metal Hydride</b>	<b>Lithium Ion Polymer</b>
Specific Energy	60-120 W*h/kg	100-265 W*h/kg
Energy Density	140-300 W*h/l	250-730 W*h/l
(Charge) Durability Cycle	180 - 2000 cycles	300-500 cycles
Cell Voltage Rating	1.2 V	3.0 V

The unit for energy density is a measurement of how much energy a battery contains compared to its volume, hence the unit Watt-hours per liter. The LiPo battery outperforms the NiMH in most analytical categories. LiPo batteries are lighter than their NiMH counterparts, and they deliver more power for longer periods. They can also be charged whether fully discharged or not. The performance advantages of LiPo are clear, but there are features where the NiMH has an edge that must be considered.

Overall, Nickel-Metal Hydride is a safer technology than Lithium Ion Polymer, as well as far more easily maintained. Trickle charging is typically used for the NiMH, which is a constant, low current in the range of  $C/20$ , where  $C$  is the current value obtained by dividing the mAh capacity of the battery by one hour. This low current allows the battery to continue charging after reaching capacity, although overcharging should still be avoided. Overcharging is a far greater concern for the LiPo battery, and is only one part of a much more complex charging and maintenance procedure.

LiPo requires specialized chargers that monitor the voltage level in each cell to ensure that that the charge in one cell does not exceed that of the others. Without this monitoring, the battery's life and performance can be severely affected. Cell imbalance can even cause instability and risk to the user or system. Overcharging a LiPo battery may result in the battery expanding or "puffing", smoking, or even catching fire. Another consideration is that a fire caused by a LiPo is a chemical fire, so it cannot be put out by regular means. This calls for the use of a fire-proof LiPo bag for charging and storage, which brings another set of protocols to follow.

Lithium polymer batteries should not be stored fully charged for more than 2-3 days. This requires having a discharger in addition to a charger. They also should not be discharged below 3.0V per cell. Ideal storage voltage is 3.8V per cell. It is all these requirements that call for complex LiPo chargers, as well as careful ownership and use.

Negative effects from improper storage are not significant in hobby use, but they will have a larger effect when considering the capacity that the A.R.V. will be used in. It is intended as a standby measure to be called upon and relied on when every second counts, but may not be called upon for weeks or months at a time. This means storage is an important consideration, as it waits for a disaster to respond to. Batteries also experience negative effects on performance from extreme weather, whether too hot or too cold. Cold weather slows down the chemical activity in a battery, while hot weather will accelerate chemical activity, causing fluid to evaporate which will damage the battery. While either battery option will need to be properly waterproofed, LiPo batteries are far more volatile in water, as well as made unsafe from chips or nicks to their exteriors.

All of the above safety concerns shift the spotlight to the NiMH battery for implementation in the A.R.V., but the extensive power requirements of the system may call for a NiMH battery that is simply too heavy to support efficient operation. It is for this reason that we will compare the best batteries we can find from each of the two technologies.

### 3.8.1.1 Portable Power for the Raspberry Pi

#### Overview

The Raspberry Pi requires its power via a good quality, 5V USB-C connector with the following current parameters.

Table 21: Consumption and Power of Raspberry Pi

PSU Current Capacity	Max USB Peripheral Current Draw	Active Consumption
3.0A	1.2A	600mA

The Pi's GPIO pins have a total requirement of 50mA, the HDMI port 250mA, and the Pi camera 250mA.

Portable chargers, which are popular bricks with USB ports and capacities in the 2,000-10,000 mAh range may be used to power the Pi, however they become

heavy and bulky as capacity increases. We will explore two lightweight options that mount directly to the board: the PiJuice HAT, and the MakerFocus Raspberry Pi 4 Battery Pack.

### 3.8.2 PiJuice HAT

The PiJuice HAT has a baseline capacity of 1820mAh via a Lithium Ion Polymer Battery for 4-6 hours of constant use. The same LiPo principles and concerns from the typical RC examples apply to this battery as well. The HAT also has support for larger, 5,000 or 10,000 mAh batteries. It doubles as an Uninterruptible Power Supply (UPS) which can protect the board from sudden data loss. This is achieved with a configured, managed shutdown that kicks in when the main power is depleted. It has a low power deep-sleep state with smart wake up, as well as onboard timers such as a watchdog that keeps it on and running. This would be useful in downtimes for the A.R.V. as mission information develops.

The on board Real Time Clock (RTC) keeps track of time whether it is powered or connected to the internet or not.,. There are RGB LEDs for battery level indication. There are even buttons that may be programmed and implemented to trigger actions via scripts. A key advantage is the header on the power supply. It allows for further expansion. Additionally, the HAT only uses 5 GPIO pins on the Raspberry Pi, leaving plenty of room for add ons before calling upon its own pins. The HAT is versatile in charging and replacement options. It will accept charge via the on board USB-C, the board's USB-C, or from the onboard pin headers. It is compatible with any single cell LiPo or Lilon battery. It is the most popular solution for portable Pi power.

*Figure 20: PiJuice HAT battery pack*



### 3.8.3 MakerFocus Raspberry Pi 4 Battery Pack



The MakerFocus Raspberry Pi 4 Battery Pack is a popular alternative to the PiJuice HAT. It is similar in concept but differs in execution. It does not offer some of the HAT's key features like headers and advanced timers, but it is significantly cheaper and accomplishes the core function of a power supply effectively. It may be charged in the on or off state and has 4 battery indications LED's - slightly more accurate than the HAT's 3 LEDs. It has dual USB output and has overcharge protection for the lithium battery. It has a capacity of 3800 mAh and can power a Pi board for up to 9 hours.

*Figure 21: Raspberry Pi Battery Pack*

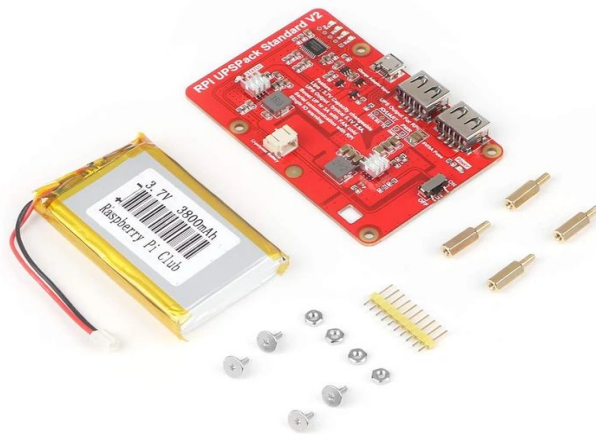

The discharge curve for the pack is below. It offers a steady voltage over 3.6V, then a steep dropoff for the last 10% of its capacity.

*Figure 22: Battery Capacity*

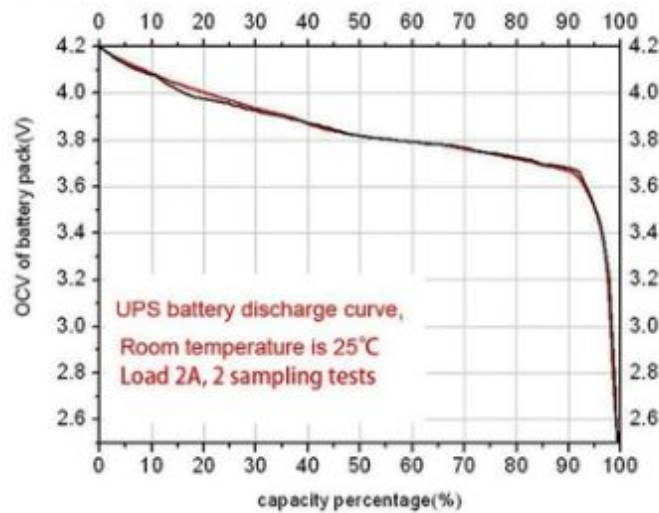

### 3.8.4 MakerHawk Raspberry Pi UPS HAT

The uninterruptible power supply by MakerHawk offers a replaceable battery option for the backup power supply. It implements two 18650 batteries. These are Lithium Ion batteries that are slightly larger than AA batteries. The board connects to the GPIO pins of the Raspberry Pi via four copper pogo pins that make contact with the bottom of the GPIO header of the Pi. There are two USB and one USB-C outputs on the UPS. There are also LED indicator lights for 75-100%, 50-75%, 25-50%, 3-25%, and <3% battery life remaining. There are several circuit protection measures in place in the UPS system. It protects against: output overcurrent, overvoltage, and short circuit; input overvoltage, overcharge, overdischarge, and overcurrent; as well as machine overheating.

A single 18650 cell has a capacity range of 1800mAh to 3500mAh in some of the best examples. The UPS requires two of these batteries, so it will deliver twice the capacity of a single cell when wired in parallel. All 18650 batteries are rechargeable, which the UPS implements as a key feature via the micro-USB charging port. It is also capable of powering the Pi via the batteries while being charged via the micro-USB port.

Figure 23: MakerHawk UPS HAT Battery Pack



The table below summarizes the comparison between the Pijuice HAT, MakerFocus RPi Battery Pack, and MakerHawk Raspberry Pi UPS HAT.

Table 22: Battery Comparisons for Selection

Specifications	PiJuice HAT	MakerFocus RPi Batt Pack	MakerHawk RPi UPS HAT
Capacity	1820 mAh	3800 mAh	3600-7000 mAh
Battery Voltage	3.3-5V	3.7 V	2.5-4.2 Volts
Cost	\$88.95	\$20.99	\$21.99
Runtime	4-6 hours	9 hours	>8 hours
Dimensions	4.33 x 4.92 x 1.38 inches	3.35 x 2.17 x 0.79 inches	3.82 x 2.24 x 0.39 inches

## 3.9 TensorFlow

### Overview

Tensorflow is an end to end open source platform for machine learning. It is a Python based, free software library for dataflow and differentiable programming across a range of tasks. Tensorflow is capable of running on single CPU systems, GPUs, mobile devices, and large scale distributed systems. It will serve as the cornerstone of the programming required for the A.R.V. to recognize a disaster on the water and react to it.

Tensorflow began its life as DistBelief, a proprietary machine learning platform. It was later simplified and streamlined, as well as made more robust. These improvements produced the Tensorflow that is available now. It can run on multiple CPUs and GPUS. The platforms that support the software are 64-bit Linux, macOS, Windows, and mobile computing platforms including Android and iOS. This is a key feature for the requirements of this project. The Raspberry Pi has the power to run Tensorflow, and Tensorflow has the flexibility to run on a mobile device, which is the end goal user platform for the A.R.V. system.

### 3.9.1 Tensorflow and Raspberry Pi

The clock speeds of the Raspberry Pi 4 allow for it to effectively explore machine learning. The increase in RAM up to possibly 8GB also supports the processing-heavy nature of Tensorflow. We may also consider a CPU fan for cooling, as the high demand of Tensorflow may cause the Pi to run hot. Installing the library to the Pi will require existence in a Python SciPy virtual environment. A virtual environment is an isolated environment for a project to have its own dependencies.

### 3.9.2 Image Processing with Tensorflow

Tensorflow supports a number of Deep Learning models. Specific to the A.R.V. application, we will implement object detection for it to detect shipwrecks or survivors. Tensorflow takes an image as input, which will be fed from a camera module mounted on the boat, with enough elevation to see out over the water surface.

Tensorflow expects a 300x300 pixel image, with three channels (red, green, blue) per pixel. This should be fed to the model as a flattened buffer of 270,000 byte values (300x300x3). Since the model is quantized, each value should be a single byte representing a value between 0 and 255. The model will output four arrays mapped to indices 0-4 with the following convention.

Figure 24: Index Mapping for TensorFlow

Index	Name	Description
0	Locations	Multidimensional array of [10][4] floating point values between 0 and 1, the inner arrays representing bounding boxes in the form [top, left, bottom, right]
1	Classes	Array of 10 integers (output as floating point values) each indicating the index of a class label from the labels file
2	Scores	Array of 10 floating point values between 0 and 1 representing probability that a class was detected
3	Number and detections	Array of length 1 containing a floating point value expressing the total number of detection results

The standard detection package contains 80 classes of objects. A technique called transfer learning may be implemented to add classes to this detection range. This will require sets of training images to teach the machine with. Transfer learning is focused on storing knowledge gained through solving one problem and applying to another related problem. For example, knowledge gained recognizing ships against glaciers or icebergs can be applied to recognize specific types of vessels.

The Tensorflow library will provide the A.R.V. with a learning foundation to build on.

## **3.10 Wireless Live Video Streaming**

### **3.10.1 Video Streaming to a Display**

In order to take advantage of the functionalities of the rescue vehicle and the live video that is captured and processed by the Raspberry Pi for object detection, it is necessary to display that processed video for it to be analyzed. This process here on out will be called video streaming. The processed video shall be streamed wirelessly to a display of our choosing which will be chosen in a later section.

It is obvious that sending the video data to a display through a wired connection is impossible due to the system being in the water. However, sending the processed video to a display is possible through various wireless methods. The method chosen is specific to the motherboard and camera module that was chosen for our rescue vehicle. Hence, since the Raspberry Pi board and Camera Module were both chosen for our vehicle, then methods for a wireless stream shall be specific to the Pi board. The process and method will be explained in the upcoming sections.

### **3.10.2 Display/Monitor Options**

A display will be needed to view the video on the rescue vehicle. Since the Raspberry Pi will be processing the video for detection of a person in the water, it is important to have a display for the dispatcher to view when a person has been found. There are various options of displays to choose from and these will all need to be considered when designing the full system. To begin the selection of a display, we will take a look at a regular LCD display monitor.

#### **3.10.2.1 Five Inch 40-pin 800x480 TFT Display**

To begin with, this display is a non touch screen device. This was chosen for a lower cost alternative and because there is no need for touch functionalities. This display is sold by third party company Adafruit and contains a 40 pin connector and cable that is perfectly suitable for Raspberry Pi boards. The resolution of the display is set to be 800x480 and contains an LED backlight which will be more than enough resolution for viewing purposes. We must also pay attention to how video will be streamed to this display as the method difficulties will be a supporting factor for choosing the perfect display option. This display screen costs \$29.95.

Choosing this display will require the purchase of a second Raspberry Pi because the display only has a 40 pin flex cable connection and does not have a built in receiver for receiving video wirelessly. Hence this will negatively impact the cost requirement for our system. Also, sending video from one Raspberry Pi to another is very tedious and unnecessary as it is possible to stream video using the original Raspberry Pi board. As a positive view, having a secondary board connected to a display allows for a better way to send sensor data along with the video. It can also be used to communicate to the Raspberry Pi that is on the rescue vehicle allowing for a larger range of usability.

### **3.10.2.2 Iphone/ Android/ PC Display**

A more convenient option for a display to stream video is an Iphone or any device that can connect to a network such as an android or a laptop. These devices are more convenient to use as display monitors because it is more user friendly and would provide no additional cost for building our system.

The iphone already has excellent display quality and resolution. However, one trade off when compared to a computer is that the iphone can display one screen at a time. This could possibly pose a problem when trying to watch the live video stream and record the sensor data at the same time. This would require two pages to be displayed simultaneously. Using a laptop would fix this problem as two pages can easily be viewed at the same time on a laptop screen.

With the tradeoffs mentioned above, it is an easy decision to include a laptop that all 4 team members already own to use as a display. It is easy to carry around and can display multiple pages and data simultaneously compared to an iphone display. It will cut costs immensely as there is no need to purchase the five inch TFT LED Display. The LED display would require extra purchases to be made since we would need a second raspberry pi. This is unnecessary and would negatively impact our goal to make the overall system to be inexpensive and efficient at the same time.

## **3.11 Bluetooth Connection**

Bluetooth technology is a form of wireless technology that uses short-range radio frequencies to allow any two devices with the technology to communicate with one another. It's known as an electronics standard, so manufacturers typically abide by specific requirements to meet industry standards. These industry standards are called the Bluetooth Core Specification and are overseen and regularly updated by the Bluetooth Special Interest Group (SIG).

Bluetooth operates at frequencies between 2.402 and 2.480 GHz with a 2 MHz wide guard band at the bottom end and a 3.5 MHz wide guard band at the top. It transmits radio signals by method of frequency-hopping spread spectrum (FHSS). With FHSS, Bluetooth divides transmitted data into packets and transmits each packet through a designated channel. Normally, Bluetooth has 79 unique channels with each channel having a bandwidth of 1 MHz. It typically achieves 1600 hops per second while using a variation of FHSS called adaptive frequency-hopping (AFH).

AFH is extremely effective at increasing resistance to radio frequency interferences by avoiding the crowded frequencies in the hopping sequence. This is great when dealing with static interference within specific frequencies within the range as all the channels afflicted with the said interference would be labelled as “bad” channels. This allows Bluetooth to avoid the bad channels in the hopping sequence. The instances when this wouldn’t be effective is if the frequency range was being afflicted by dynamic interferences in the system. If the “good” and “bad” channels within the frequency are constantly changing, then AFH won’t be effective at avoiding the interference in the system.

The minimum transmission range of a given Bluetooth device is typically less than 10 meters (33 ft), but there isn’t a definitive upper limit for range, although larger distances negatively impacts data transfer rate as well as the power consumption. The ranges of Bluetooth devices are divided by classes. These classes are as follows:

*Table 23: Ranges of Bluetooth Devices by Class*

Class	Maximum Permitted Power		Average Range (m)
	(mW)	(dBm)	
1	100	20	~100
1.5	10	10	~20
2	2.5	4	~10
3	1	0	~1
4	0.5	-3	~0.5

## 3.12 UART

UART stands for Universal Asynchronous Receiver/Transmitter. It's a computer hardware device, typically part of an integrated circuit, responsible for asynchronous serial communication that utilizes configurable data formats and transmission speeds. There are commonly one or more UART peripherals integrated into microcontrollers.

The UART deconstructs bytes of data and transmits the individual bits sequentially. Once at the destination, the UART that received the data reconstructs the bits into complete bytes. This is done as it allows UART devices to communicate via serial transmission, which uses only a single wire rather than parallel transmission, which uses multiple wires. UART devices utilize shift registers to convert between serial and parallel forms, and this ultimately results in the UART being less costly. Communication can be either simplex, half-duplex, or full duplex.

## 3.13 Wi-Fi

WiFi is a set of wireless network protocols based on the IEEE 802.11 family of standards, which is most known for its common practice use for local area device networking and for internet access. Wi-Fi stations use data packets, which are blocks of data, to communicate with each other. These packets are individually sent and received over radio via carrier waves, which is a modulated waveform with the purpose of conveying information.

Wi-Fi uses different techniques, depending on the version, to send these carrier waves. The most recent version of Wi-Fi, Wi-Fi 6, uses orthogonal frequency-division multiplexing (OFDM). OFDM is a type of digital transmission that uses multiple carriers that are on slightly different frequencies within the channel as a method of encoding data.

Wi-Fi channels are half-duplex, which means that two devices connected through a Wi-Fi channel can both communicate with each other, but not at the same time. If multiple networks attempt to use a channel simultaneously, the channel will be time-shared, meaning that the networks will take turns using the channel for an allotted amount of time. When two stations attempt to transmit simultaneously, that is known as a collision. In the event of a collision, the transmitted data becomes corrupted, and the stations are required to re-transmit. This reduces throughput, and in some instances, by a significant amount. To prevent such an event, carrier sense multiple access with collision avoidance (CSMA/CA) is used, which is a scheme that is used to handle how computers share a channel. It makes attempts to avoid collisions by having nodes begin transmission only



when the channel is detected as “idle”. Once idle, nodes transmit all of their packet data at once. While there are still chances where collisions may occur, this does reduce the possibility by a good margin.

Wi-Fi stations are programmed with a globally unique address known as a MAC address. MAC addresses are 48 bits in length and are used so that both the destination and source of all data packets can be specified and traced. Wi-Fi establishes connections using the destination and source addresses. When a device receives a transmission, it uses the destination address to determine if the transmission was meant to be sent to that device. If the aforementioned device’s address does not match that of the transmission’s destination address, the network interface most likely does not accept the packet as it was likely meant to be sent to another Wi-Fi station.

The operational range of Wi-Fi depends on several different factors such as frequency band, transmitter power output, receiver sensitivity, antenna gain, antenna type as well as modulation technique, but overall, Wi-Fi is capable of achieving far greater distances than Bluetooth. In general, longer distances means that the speed of transmission is reduced. For Wi-Fi signals, line-of-sight is best for communication between devices, but not necessary.

Wi-Fi transmitters are low power devices. While the maximum power that a Wi-Fi device can transmit is regulated at a local level, the European Union limits the maximum power to 20 dBm or 100 mW. While Wi-Fi is still considered to take up relatively little power, it should be noted that due to Bluetooth’s shorter propagation range, Bluetooth’s power consumption is lower.

### **3.14 Static IP address vs. Dynamic IP address**

In order to remotely connect to the raspberry Pi board through any wireless method, the IP address of the Pi will be needed. Hence, it is important to understand the difference between Dynamic and Static IP addresses. A dynamic IP address means that the address can change at any time. When connecting remotely to the Raspberry Pi, it will be repetitive and inefficient to update the IP address every time the address changes or everytime the board is turned on. Hence, we must consider changing the settings from dynamic to static.

A static IP address does not change. Hence, we can assign a permanent address on the network to the Raspberry Pi. This process is rather simple and can be viewed in the section below.

## **4.0 Standards and Design Constraints**

This section will outline the importance of design constraints and design standards. Various constraints and standards that relate to our Autonomous Rescue Vehicle design will be explored.

### **4.1 Related Standards**

Standards are documents, forms, or any type of description of a certain product that establishes clear outlines and features for a product or service. Standards are one of the most important applications in any product whether a company is selling it or a single designer is building it. Applying standards to products help guarantee that they are safe to use, effective, compatible, and most of all environmentally friendly or unfriendly. Standardization is usually released from national or international organizations such as the International Organization for Standardization (ISO) and International Electrotechnical Commission (IEC).

It is important to understand that there are many other associations all over the world dedicated to the creation of such standards. Some regulations and standards even come down to specific companies. There exist standards and regulations for every type of product or service, from screws and nails to air planes and cars. Hence, the reason for the plethora of committees.

For our design project, the Autonomous Rescue Vehicle, standards will be gathered through two organizations. The American National Standards Institute (ANSI) and IEEE Standards Association. For our design project, most standards will come from IEEE and will be used to ensure all safety and regulations are up to date in our design.

#### **4.1.1 1679.1 Evaluation of Lithium Based Batteries**

For the purpose of our design, this standard will be focused primarily on the Lithium Ion Polymer Battery or LiPo. Lithium Ion Polymer is a lithium-ion cell contained in a soft pouch where the electrolyte is gelled by using a polymer additive. When charging lithium ion batteries it is important to charge them specifically with the matched charging device. For safe operation of a LiPo, it is important to only use the charger that is provided with the battery system.

LiPo batteries are always sealed for the prevention of moisture contact from the atmosphere. There should be no effect from any environmental variables such as salt from the ocean, water spray, or rain. Hence, it's important to prevent any destruction to the concealment of the battery. The battery must be placed in any application with proper care so that continuous vibration, thermal cycling, and

shock will not cause damage to it. In section 5.10.1 of the related standard, constant monitoring is required for any lithium based battery.

It is also important to understand over-discharge and overcharge. Over-Discharge occurs in a battery when the cell voltage falls below a critical value limitation. This allows for the copper from the negative foil of the battery to dissolve into the electrolyte. Once the battery is recharged the copper comes out of the solution and creates tiny shorts causing the battery to not function. hence , it is important to understand the type of application the battery will be used for.

Some applications allow for operation with a minimum battery voltage. If this continues for a prolonged period without the battery being discharged, then over discharge will occur. Overcharging a battery is the result of the voltage being significantly higher than the recommended operating condition. It is important to follow charging rate limits to prevent cell damage and catastrophic failure.

Before using lithium based batteries in any application, the user should be responsible for knowing all potential safety hazards and issues. Abuse tolerances help eliminate discrepancies on how to handle LiPo batteries. Abuse testing includes electrical abuse, environmental abuse, and mechanical abuse. These tolerances help determine the risk of surrounding equipment in the application in order to prevent any injuries or equipment damages.

Lastly, it is important to know specific fire codes for lithium based batteries in case of a damaged battery or a catastrophic event. Both the International Fire Code (IFC) and National Fire Protection (NFPA) have specific requirements for lithium batteries. Disposal of batteries and regulations are required to be followed and is regulated for environmental control. Lithium based batteries cannot be disposed of in household waste because of the organic chemicals in the electrolyte. It is also dangerous to throw them away in unknown waste because these batteries contain active materials and can cause shorts and fires.

## **4.1.2 Battery Standard Design Impact**

The battery standard discussed in the earlier section significantly impacts how we properly handle and use the LiPo battery for our design project. The Lithium Ion Polymer battery is the main component of the entire system. Without this battery, the motors of the boat will not function and the main goal of the system will not be reached. Hence, it is important to follow the guidelines that were established in the IEE Lithium battery standard.

Over-discharge and overcharge impacts our design application by setting a higher limit voltage for the system to function. If we allow for operation of the

vehicle for a prolonged time with the battery under critical voltage values, then we can run into the possibility of shorts and failures.

Since the battery is already sealed and lithium based battery standards state that they are safe from environmental effects, there is no reason to limit the conditions that the vehicle can operate in. However, abuse tolerances from the battery standards will affect the location and placement of the battery in our system. Precautions must be taken to prevent the battery from constant vibrations, shocks, or any shorts from touching other equipment in the system.

### **4.1.3 12207-2017- Software Development Standard**

Software development and software systems have continuously increased in complexity throughout time and continues to progress. As a result, new challenges exist in creating an approach for tackling the softwares architectural design. This standard helps integrate all disciplines and groups to achieve a functional software design that meets the needs of the application.

This standard will pose comprehensive sets of procedures to follow in order to provide a structural and workable environment for developing the software. For our design project, this standard will be useful in writing software that processes video ford object detection and autonomous vehicle movement. Creating a structured software application that has a high efficiency is important for our design as the rescue vehicle will be processing data and following coded instructions simultaneously.

According to ISO/IEC TS 24748-1, a typical software development life cycle includes a variety of stages. It begins with concept, and continues through development, production, utilization, support, and retirement. Understanding each progressive stage gives rise to making individual decisions and achieving milestones set out for the specific program. This reduces risks and uncertainties in cost, scheduling, and utilization of a new software.

This standard helps reduce uncertainties when dealing with the overall software application in our rescue vehicle. It is important to understand how to analyze and assess the needs of each software application related to a project. It is also important to know how to improve the process of working on development. The IEEE standard calls out 3 important factors when analyzing and assessing the process which will aid in our own development for our design project.

The first factor is to monitor performance of the group and the software being created. The second factor is to conduct periodic reviews to process any achievements and progressions. Third factor is to identify any improvement opportunities from the assessed results. It could be difficult to find ways to

improve software development because it is already difficult enough to organize and develop an original project. However, the standard outlines specific tasks that will be beneficial to our design project. Prioritizing and planning will eventually lead to new lessons learned. Once these lessons are learned, improvements to any design are captured and easily achieved.

#### **4.1.4 1609.0 Wireless Access in Vehicular Environments**

This IEEE standard outlines specific regulations for wireless access in vehicular environments. It specifies that wireless access or transmitting data via wifi from a vehicle is a radio communication system that intends to provide short range communication between devices (DSRC). This standard is vital to our design project as our rescue vehicle is a vehicle transmitting data short or long range distances wirelessly. IEEE calls these standards the WAVE standards and were developed to provide support for transportation safety, efficiency, and sustainability. Sustainability and environmental effects are crucial to our design project as it will be set out in water and eventually the ocean for rescue.

Within the standard 1609.0, IEEE calls out a related standard that applies to networking services for wireless transmission that includes many features. It outlines proper ways for WSA transmission and the use of Internet Protocol version 6 (IPv6) including streaming. It also outlines how to manage information and data that is communicating between the two devices.

Short range communication messages are specified in the SAE DSRC standards. They are important to understand for communicating short range data that is intended for vehicle-to-vehicle and vehicle-to-infrastructure. It includes specifications for safety exchanges between the two devices and the proper way to implement the messages.

In order to classify a proper WAVE system, the IEEE standard specifies how the system application should offer safety and convenience to intended users. It should support and offer users greater situational awareness, potential threats, and hazards. Transactions between vehicle and hand-held devices should support a network with low latency. With a low latency requirement for this standard, the US. FCC allocated a spectrum band at 5.9GHz in order to support these types of applications.

There is no requirement for secure communication, however, depending on the application one should lean towards a secure environment for safety options to intended users. Lastly, the WAVE standard describes a protocol for short messages of data transferring. This allows for applications to directly control characteristics such as the transmitter power and channel number. It provides

access to the PSID and MAC address of the destination that the data is being sent to. Short message data exchanges are outlined in the IEEE standard as follow:

- An application acting as a source creates WSM data for transmission purposes. It then addresses it to the MAC or PSID address.
- Based on any configuration that was assigned, the application or software should select an appropriate radio channel to control the transmission of data.
- A device dedicated for receiving data accepts the package and sends it to the communication stack.
- Based on the PSID, the WSMP then delivers it to the receiving entities.
- Finally, the receiving device whether infrastructure or hand held, knows the existence of the data package and the address of the originating vehicle and continues the exchange continuously. This can be done through unicast or broadcast.
- It is important to note that the same process can be said for internet protocols to support IP version 6 (IPv6)

## **4.1.5 Wireless Access Standard Design Impact**

The wireless access in vehicular environments architecture standard impacts our entire design approach for wireless communication and data transfer. It allows us to properly communicate and exchange data between devices the correct way that follows regulations. Our rescue vehicle is a water based vehicle for any type of water, such as a lake or ocean. Hence, environmental and safety standards are crucial for our design and the wireless access standards help minimize any environmental issues we will encounter.

Our vehicle will constantly be sending data wirelessly through wifi and streaming video is a main feature for our design. In standard 1609.0, specific protocols for proper ways of WSA transmission and the use of Internet Protocol version 6 (IPv6) are established. Streaming is also included in these protocols and will help us understand proper ways to stream video based on these standards.

Our project design will include short range wifi data transmission. Long range transmission will be a goal for an updated model of the rescue vehicle, however, both long range and short range communication falls under the same WAVE standards and impacts our design. The standard calls out that the system should contain proper ways to establish greater situational awareness for its intended users, find potential threats, and contain any safety hazards.

This only confirms that our rescue vehicle will have no problems following this standard because it will continuously stream video and live object detection

which creates the intended situational awareness. Potential threats are continuously taken care of as the boat finds any person in need of rescue. Lastly, hazards are quickly monitored as the vehicle continuously sends data related to depth of the water to prevent any unwanted risk in a rescue attempt.

### **4.1.6 IPC - PCB Standard (Printed Circuit Board)**

PCB standards are widely used for manufacturers to print reliable and regulated circuit boards. Common standards that provide reliability for the user and safe handling are acceptable methods for hardware installations, acceptable soldering and requirements for through-hole technology on circuit boards and surface mount parts. PCB standards are established through IPC or Association Connecting Electronics Industries. IPC regulates many standards that manufacturers of PCBs need to follow for producing reliable products and circuit boards that will last for a long period of time.

The most widely used standard for manufacturers is IPC-A-610 - Acceptability of Electronic Assemblies. This standard outlines the proper handling of PCBs and acceptable methods for installing and soldering parts to the board. IPC-A-600 - Acceptability Standard for Manufacturing, Inspection, and Testing is a standard that outlines how to assemble circuit boards and the proper way to inspect them after the build. This ensures that manufacturers handle circuit boards with care so that no failures arise and reliability can remain balanced. Inspection of proper coating, wiring, and layers are specified in this standard.

These IPC standards affect the project design by increasing reliability with manufacturers that are preparing the circuit boards. These standards allow for the possibility of catching the smallest manufacturing imperfections and fixing the problem before it exists. It reduces risk of overlooking proper PCB handling and helps avoid electrostatic discharge (ESD).

## **4.2 Design Constraints**

Constraints are an important factor in any design project whether it is for engineering or for a business model. Constraints are essential to provide realistic views on anything that can happen during the design process, during system testing, and during the use of the product or service. All constraints will be applied to the design in order to provide a better and efficient system. There are various realistic design constraints for the autonomous rescue vehicle.

## **4.2.1 Economic and Time Constraints**

In order to provide a quality design for users of the autonomous rescue vehicle, it is important to understand how the cost of designing the system affects its performance. Cost plays a major role in any product or service and is a huge constraint for our team this semester. In the summer semester, there are no sponsorships available and no funding to be received from a sponsorship.

Finding funding from a company on our own would be risking valuable time for designing our project. Hence, cost will be the responsibility of the group for anything related to the project. This will ultimately affect the marketability because if cost for design is higher, then the cost in the market will increase as well. Also, this economic constraint will affect the overall testing process and lead to spending more time on accurate research.

Due to lack of good funding, more research will have to spend and more time gathering the right components to work in the design. It will be unwise to buy components for testing and not being able to make them work together. Hence, in order to make sure all components and parts are well suited for the design, more time must be taken in research. Ideally, the autonomous rescue vehicle would maximise its performance by using high quality components, however due to the economic constraint, we must settle for a lower cost system.

Time constraints are also an important factor to keep in mind for our design. As can be seen in our milestone section of this report, completion of all research, schematic design and major component testing must be completed by August 1, 2020. Building of the rescue vehicle will begin in August of 2020 and must be completed by December of 2020. Realistically, with more time, any design can reach much greater quality in regards to performance and reliability. However, with the time constraint, we are restricted to a design method that will help build our rescue vehicle at a quicker pace.

## **4.2.2 Environmental, Social, and Political Constraints**

The biggest constraint for any design in the modern world is renewable energy. Our rescue vehicle will constantly be used in ecosystem environments such as oceans, lakes, or rivers. Hence, environmental safety and clean energy is very important to consider in our design. All parts used in our design would not affect the environment in any way as no harmful gasses or liquids will be released from the system.

The LiPo battery that powers the entire system is rechargeable, and does not need to be thrown away unless damaged. Our main focus of the project is not to provide a clean energy vehicle, however, large scale design aspects shall include



a solar powered device. Switching to solar power will provide for extended use in the ocean with no need for system maintenance. Overall, the environmental constraint does not alter our design in any way.

The rescue vehicle shall provide its users with accurate results and data that is reliable. Its main purpose is for rescuing any one that is in the water in need of help. Hence, social constraints play a strong role in the effectiveness of our design due to making our product transportable and affordable. The product should not be limited to only certain users.

The product can be used for more than just rescuing as well and can tackle any detection needed once it is programmed with requested object detection. Our design will surpass the limitations set by the human eye when searching for anyone in a body of water. Thus, it is suitable for any user that is working in this type of field and provides no effect from social constraints.

Political constraints always differ for any product as it depends on what the system is doing. For our design, testing and demonstrating the final product will rely on political constraints. In order to properly test and demonstrate our project design in December, we will need to use UCF pond in front of the library to run our system. This will require permission from UCF officials. Hence, we must be mindful of any regulations regarding the use of the UCF pond.

There is also a possibility in connecting the raspberry pi to the school network. This might require the address. However, if any restrictions arise, we are prepared to switch methods in order to connect our rescue vehicle wirelessly through a smart phones hotspot.

### **4.2.3 Ethical, Health and Safety Constraints**

All engineers shall follow all ethical rules and never cut corners while designing any system. All standards and regulations in the environment intended for use must be followed. Our rescue vehicle uses non toxic material and provides measures for allowing for longer use in system performance. One such measure is the ability to monitor decrease in battery life from the LiPo battery that powers the system.

As discussed in the Lithium Ion battery standards, it could be harmful to operate any system under low voltage levels. Hence, for ethical reasons, we will not allow the operation of the vehicle once this lower voltage level has reached. Alternative battery packs will be used if the primary battery were to ever fall below the limit. Lastly, thorough research will be done by the team to make sure no copyrighted patents are reproduced in our design by mistake or any copyrighted material is reproduced in this report.

Health is a primary concern for not only who uses our product, but for everyone on the planet. That being said, health constraints will affect our system design significantly because we will provide measures to never undercut power levels from our primary battery pack. This will be hazardous as the lithium ion battery can be corrupted and hazardous with continuous use at low battery levels. Hence, our system will respond to this health constraint by providing a monitoring line that switches to a secondary battery pack once the microcontroller detects a set voltage level outputting from the LiPo battery.

This semester, health is also a primary concern for the team designing the rescue vehicle. Due to the coronavirus outbreak, proper measures will be akin when testing in public environments and all meetings will be handled with caution. It is important that we all stay healthy in order to be effective in the design of the rescue vehicle and be able to finish the entirety of the project.

Safety is the primary purpose of our entire system design. This project is intended to surpass the limitations of human eyesight abilities and autonomously search for people in need of rescue in a large body of water. Safety constraints are the most important focus during the design process and building of the rescue vehicle.

This constraint will tighten our specification requirements for sensor data. Long delays or wrong analysis during object detection can result in safety hazards and failure of what the system was meant to provide for its end user. Hence, data from sensors will be very accurate and the delay between data transfer from the rescue vehicle to the display will be cut to a minimum.

Safety concerns can also be attributed to any equipment that is faulty or for bad placement of parts. Shorts can happen anywhere in the design if we are not careful which can lead to fires and toxic chemicals from the LiPo battery. This is a problem both for safety constraints and environmental constraints. Hence, safety will be taken very seriously when designing the boat architecture and placement of parts will be thoroughly planned.

The LiPo battery will be placed in a manner that vibrations and water damage will never cause any harm. It will also be screwed tight in the inside of the boat so no movement or shock can contribute to malfunction of the battery. The charging wires for the battery will be placed in a way that is safe and easily accessible for charging requirements. The placement will be such that the user would not have to remove the battery completely from the boat. This removes the harm of putting the battery the wrong way after charging.

## **4.2.4 Manufacturability Constraints**

Manufacturability is a required process in all designs and is a constraint that the team must take into account for our rescue vehicle. All parts that were researched and selected as a component can go out of stock at any time. Hence, this played a role in having secondary components researched and ready to add to the rescue vehicle as replacements if this were to ever happen during the building process.

Manufacturability also plays a role in our pcb design as we are constrained to low cost manufacturers for pcb products. Due to Covid-19, many components are out of stock or have lead times. This affects our time to be ready for building the rescue vehicle. Hence, we must be prepared for alternate parts that also work with the same efficiency.

## **4.2.5 Sustainability Constraints**

Sustainability is important in any product being designed. It is important not to cause harm and protect any ecological or economic foundations. For our project design, we implement safety measurements to make sure battery life is always charged for ample system efficiency. These safety measures were previously discussed in the safety constraints section. All parts ordered and the overall system design shall follow specific guidelines for careful use of the system so that it can be sustainable and have a long lifetime. All other factors related to sustainability constraints do not apply to our project design.

## 5.0 Hardware and Software Design

### 5.1 Power

#### Overview

The primary source of power for the boat will be a rechargeable battery in the range of 7.2-11.1 volts. We will explore typical batteries seen in RC applications. It will consist of multiple cells that have a common individual voltage rating, wired in series to sum to a desired output voltage, The objective in assembling the power supply is a minimum system run time of 8 minutes, the system being the boat and all onboard components.

Voltage will need to be regulated to different levels based on the operating requirements of each component. We will implement voltage regulators and DC-DC converters for this task, and explore the working components of these essential tools. While these are options for the measurement and detection components of the A.R.V., the heart of the system, the Raspberry Pi 4, requires a 5.1V input voltage via USB-C. This will call for a dedicated department in the working office of the A.R.V. power system.

### 5.2 System Components Power

The power system for the A.R.V. will be integrated into the hull of the boat, along with the control, and transmit/receive components. It will need to be size conscious, as hull space is limited, and undeniably waterproof. This is where the cornerstone for our PCB design will be laid. All components that require a power supply for functionalities are listed in the table below. This table will outline all the voltages needed in order to operate the full system. This allows us to accurately design DC-DC converters that will regulate the correct voltage for operation. As will be shown below, the MSP430 requires 3.3V for turn on and has a max current of 5.3mA. Since the battery back that was selected outputs 7.4V, a step down converter (buck) must be designed to regulate the voltage to 3.3V.

There are two other components that have the same power requirements as the MSP430. The oscillator that is used for the depth sensor design and the gps module both require 3.3Vcc. This is the best possible case as this would decrease the amount of components needed on the PCB and is one less regulator requirement for the design. The DC to DC converter chosen must meet the requirements for max current ratings of the devices. As shown in the table the MSP430 max current rating is about 5.3mA. Hence, the regulator should be capable of outputting enough current for all 4 devices that are being supplied.

The raspberry Pi has a voltage requirement of 5.1 volts and will be powered by a separate battery pack due to current draw. The Motor will be connected to the motor driver, hence there is no need to worry about the current draw from a regulator supplying the voltage. The raspberry pi camera module also has a 3.3V operating voltage like most of the components in our system. However, the camera will be interfaced using a flex cable and connected to an on board connector that is already placed on the raspberry pi board. Hence, there is no need for designing hardware, schematics or a regulator for this part.

Lastly, the motor driver that allows the microcontroller to control motor speeds draws a lot of power with a current draw of 2A. Hence, this will not come from any regulator on board but directly from the 7.4 LiPo battery that will be mounted inside of the boat. This is possible because the motor driver input requires a range of 5V to 12V. This wide range is possible because it has an onboard 5V regulator for the enable pins.

Table 24: Powered Components in the A.R.V System

Qty.	Part	Operating Voltage	Max Current	Power
2	Motor	5V-9V	500mA	2.5W - 4.5W
1	MSP30F5529	3.3V	5.3mA	17mW
1	Raspberry Pi 4	5.1V	1.2A	6.12W
1	Pi Camera	3.3V	480mA	1.58mW
1	GPS Module	3.3V	67mA	22mW
1	Wifi Module	3.3V	250mA	825mW
1	Motor Driver	7.4V	2A	14.8W

## 5.3 DC-DC Converter 3.3V

In order to provide efficient power constantly to all of our sensors and microcontrollers it is important to understand the current draw from each load. This can be seen from the section above and gives us a rough estimate on the max current output that will be set for the regulator that will be designed. The DC-DC converter will be designed using TI's Webench Power Designer Tool. This tool allows us to input regulator requirements and then offers multiple types of regulator designs that meets your application needs. In order to provide our system with low heat and more efficiency, we will select a design with an efficiency rating greater than 88%. This is helpful so that the regulator on the PCB won't get too hot.

The most important input parameter for the DC-DC converter design is the input voltage range and output voltage needed along with the max current output. In order to leave wiggle room for performance or any other additional power requirements that could be added that was missed, the input range requirement for our design must be within 5V to 12V. In order to improve the performance of our system in the future, this input range must be included in case of a higher voltage battery replacement. Instead of using a 7.4V LiPo battery, an 11.1V LiPo can take its place for higher motor speeds in bigger designs.

All of the sensors and the MSP430 microcontroller that will be interfaced together will require a 3.3V power supply in order to turn on and operate. Hence, the regulator must efficiently output 3.3V with a low ripple. The power consumption table by component in the table above helps us determine the max current output of the voltage regulator that will be needed. Lastly, in order to help stay within the design's cost requirements the design chosen will be low cost. Another important factor would be designing a small footprint to save pcb space for other components.

Efficiency and cost go hand and hand. If a high efficiency rating design is needed then the price will go up. Hence, in order to stay within the cost requirements, an efficiency level of 90.2% was chosen. The cost of this design was over 2\$ more than that of a efficiency rating of 84%. For better performance, it was decided to choose a higher rated regulator. However, the total price was still low enough that multiple quantities of each component in the BOM can be purchased.

Using the Power Designer tool from TI, the 3.3V regulator schematic can be seen in the figure below:

Figure 25: DC-DC Converter Schematic 3.3V Output

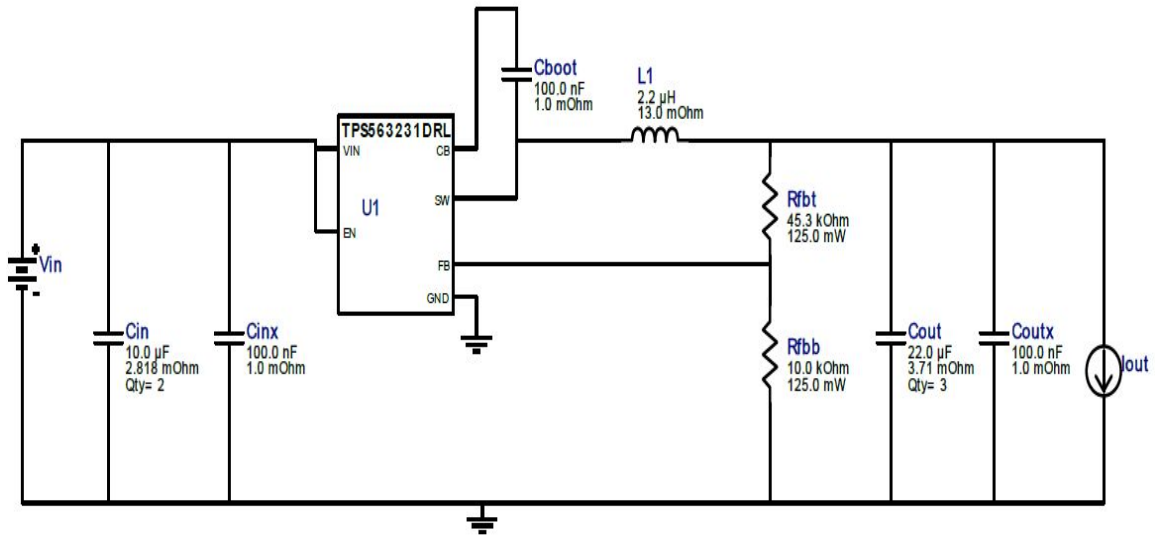

As seen from the schematic above, the regulator is a buck converter which steps down the voltage to 3.3V. Performance and operating values can easily be analyzed from the Webench program. Texas Instruments provides a complete operating table that summarizes all the performance details for all components used. This is important to view because we need to understand how this circuit will operate on the PCB when mounted. Before outlining specific operating conditions and performance, a block diagram describing how the voltage regulator will be supplied to different sensors and loads can be seen in the figure below.

Figure 26: Regulator Input and Output Loads Diagram

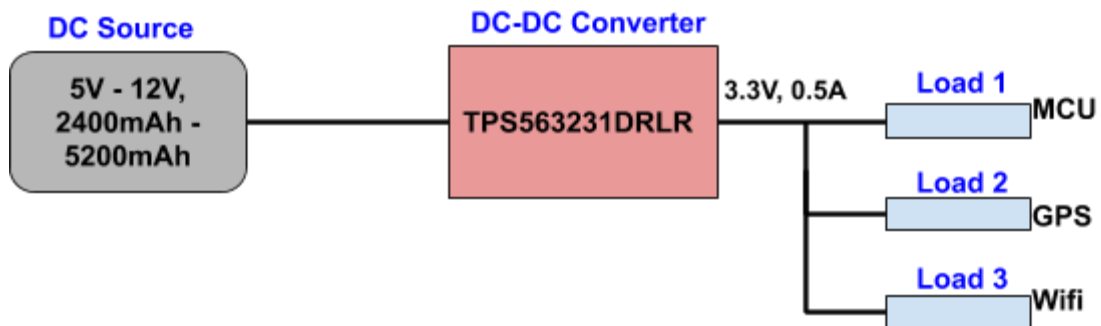

As previously discussed, the block diagram outlines a DC source in a wide voltage range in order to account for power adjustments for scaling up the design in future systems. The source is connected to the DC converter that will step down the voltage to 3.3V and limit the output current to 0.5A. The power is then distributed amongst the 3 loads that require a 3.3V input. The wifi module will consume the most current during turn on. The Wifi module datasheet has a peak

current draw at 250mA during initialization of the device. Hence, it was important to make the max current output large enough to accommodate for this large current draw.

A BOM list is important to have an overall cost estimate of any design. The Webench tool exports a BOM with the customizable components that were selected in the design that was chosen. The initial design for the 3.3V regulator contained components with a 0402 SMD size. This was too small for our design requirements because it is too small to solder without using a microscope for better handling. It is possible to solder the small component without a microscope however, we risk damaging the component and the PCB if we do not handle it correctly. Also, DigiKey (an electronics and hardware component website) was used to make sure all parts on the BOM were in stock and ready to ship. Many initial components were not available which caused us to search for alternative parts until one was found available. The overall BOM and total cost can be seen in the table below.

Table 25: BOM for DC-DC Converter

Part	Manufacturer	Part Number	Cost	Quantity
Cboot	Yageo	CC0805KRX7 R7BB104	\$0.02	1
Cin	TDK	C2012X5R1V1 06K085AC	\$0.17	2
Cinx	Yageo	CC0805KRX7 R9BB104	\$0.02	1
Cout	TDK	C1608X5R1A2 26M080AC	\$0.12	3
Coutx	Yageo	CC0805KRX7 R7BB104	\$0.02	1
L1	Bourns	SRN8040-2R2 Y	\$0.27	1
Rfbb	Vishay-Dale	CRCW080510 K0FKEA	\$0.01	1
Rfbt	Vishay-Dale	CRCW080545 K3FKEA	\$0.01	1
U1	Texas Instruments	TPS563231D RLR	\$0.22	1



In order to properly investigate whether this regulator is the best option for our system, a table of operating values and other specifications will be listed in the table below. This will allow us to fully grasp the operating points that will be going on during system operation and can help us troubleshoot any problems that could arise during system testing. Processes and steps that will be taken for Trouble-shooting any problems that can arise on the regulator can be seen in chapter 6 of this document.

Table 26: Operating Values for DC-DC Converter

<b>Name</b>	<b>Value</b>	<b>Category</b>	<b>Description</b>
BOM Count	12	---	Total Design Bom Count
Total BOM Cost	\$1.27	---	Total BOM cost
Cin IRMS	389.224mA	Capacitor	Input Capacitor RMS ripple current
Cin Pd	213.46 $\mu$ W	Capacitor	Input capacitor power dissipation
Cout IRMS	609.866 mA	Capacitor	Output capacitor RMS ripple current
Cout Pd	459.96 $\mu$ W	Capacitor	Output capacitor power dissipation
Coutx IRMS	2.806 mA	Capacitor	Output capacitor_x RMS ripple current
Coutx Pd	7.871 nW	Capacitor	Output capacitor_x power loss
IC Ipk	1.438 A	IC	Peak switch current in IC
IC Pd	158.78 mW	IC	IC power dissipation
IC Tj	39.527 degC	IC	IC junction temperature
Iin Avg	151.48 mA	IC	Average input current
L Ipp	1.876 A	Inductor	Peak-to-peak inductor ripple current
L Pd	8.13 mW	Inductor	Inductor power dissipation
Cin Pd	213.46 $\mu$ W	Power	Input capacitor power dissipation
Cout Pd	459.96 $\mu$ W	Power	Output capacitor power dissipation
Efficiency	90.77%	---	Steady State efficiency
FootPrint	168.0mm	---	Footprint Area
Frequency	304.824kHz	---	Switching Frequency
Iout	500mA	---	Iout operating
Pout	1.65W	---	Total Output Power

## 5.3.1 Regulator Testing

Testing the DC-DC converter circuit is the last and most important step. It is necessary to establish a testing outline in order to follow the correct steps for testing if the regulator works properly. Ideally, all the parts from the 3.3V schematic would be ordered for through hole parts and tested on a breadboard before surface mount parts are purchased. However, the IC (Regulator Part) does not have a through hole packaging option. Hence, we must test a 3.3V regulator using another component and assign multiple loads to the regulator for power consumption testing. Once that test is complete, surface mount parts will be purchased for soldering onto the PCB that was designed and purchased.

The figure below outlines the correct way to test the voltage regulator. The first step is to connect the input power supply to the input of the regulator and connect all loads one at a time to the output. To voltage should be measured across the input lines and the output lines for confirmation of correct voltages that are required from the regulator. Next, a current probe should be placed across the output line to measure the current consumption coming from the output of the regulator to the load. This should be tested for all loads individually and then all loads connected together. The exact outline diagram can be seen in the figure below.

Figure 27: Diagram for Regulator Testing Requirement

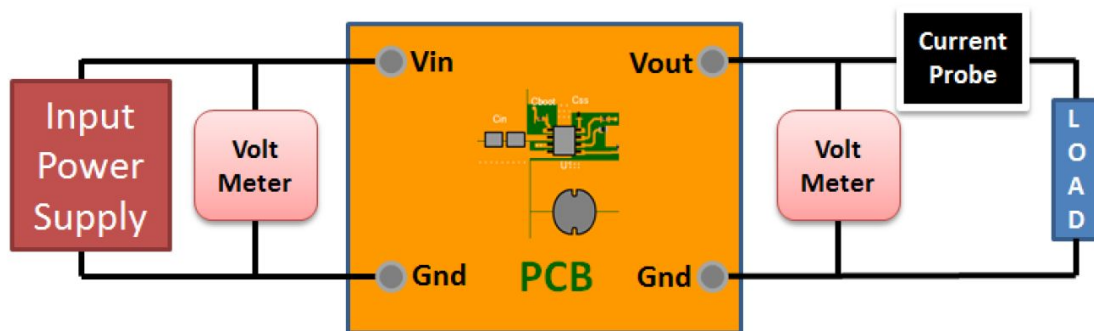

## 5.4 Motor Control Design

The motor of the ARV is a very important component and must be designed properly so that the user can interface with the boat correctly. Without using a motor driver and using the logic communication pins with the microcontroller, the user will be unable to direct the vehicle autonomously. Hence, a driver module with two motor outputs is used in order to control the two motors using the MSP430.

The first step of the design is using a battery that can supply enough voltage to power the motor to its full potential. The motor is approximately 6V, however, the driver used to control the motor using an H-bridge contains two MOSFET's that have a voltage drop of 0.7volts. Hence, the voltage required is 7.4V for full motor potential. This is the reason a 7.4V LiPo battery was chosen. The input of the battery should be connected to the Vcc pin and GND pin of the motor driver. The driver contains an optional 5V pin which acts as either an input or an output. If the 5V jumpers on the board are enabled, then the pin acts as an output. This is due to the 5V regulator that comes installed in the module. This is very useful for building the boat and future design adjustments in case of a 5V requirement.

The driver contains two motor connector inputs that can be used as a Motor A and Motor B connection. These pins are where the motors followed by the propeller will be connected to. In order to interface with the motor speeds, the driver has 5 logic pins that are used to interface with a microcontroller. In our case, the MSP430 will be used to communicate with the motor driver. The first two pins are enabled pins followed by 4 input pins. All 5 pins must be connected to a digital out pin on the microcontroller capable of pulse width modulation.

Once all communication pins are connected, controlling the motor's speed and its direction is simple. A pulse width modulation signal is needed so that the enable pin turns on and off when the user requires it to do so. When the pulse goes high, the enable pin gets set to 5V through the onboard regulator. This turns on the motor. The input pins 1 through 4 are used to set a speed or set a direction that the motor is spinning. This is repeated for the second enable pin for motor B. The block diagram for this entire motor design outlines how to interface with the module using an MSP430 and how to set up all connections for power and communications. The figure can be seen below for a better understanding of the design.

Figure 28: Motor Interface Design Block Diagram

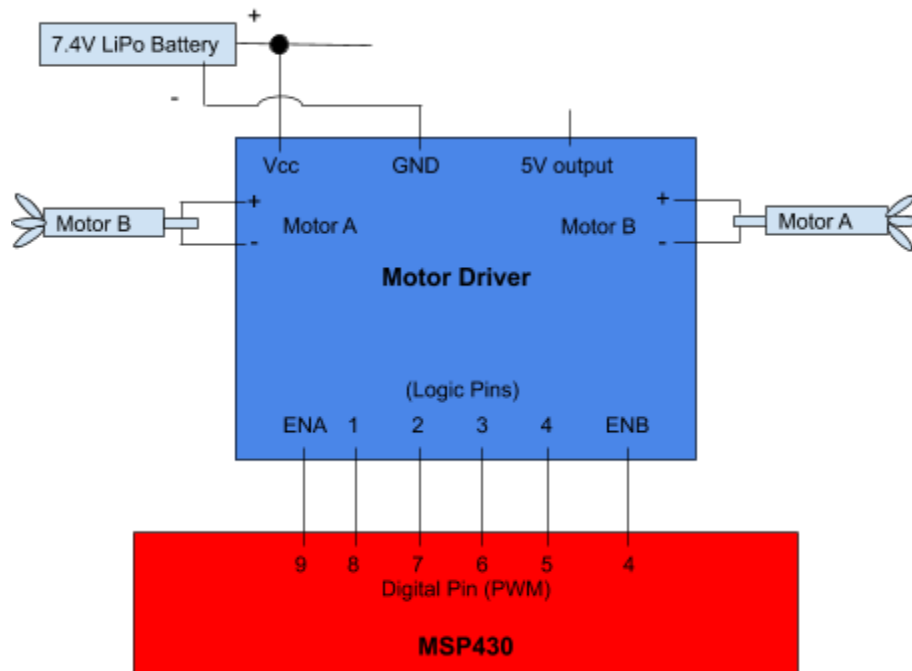

## 5.5 GPS Design and Integration

The gps module is a very important component for our overall system. Without this design fully functioning, the system will never be able to fully accomplish what it is intended to do. GPS location is important so that the user can constantly know the location of the vehicle. When the ARV detects a person in the water, the user must know where the found person is located. Hence, this design must be flawless and very precise. If the GPS location has a larger tolerance on the longitude and latitude, then it could lead to a non rescue or even arriving for the rescue too late.

As was stated previously in the power section, the GPS module requires an input power of 3.3V. Hence, it must be supplied by the DC-DC converter that was previously designed. For interfacing purposes, the GPS module has 2 pin outs. A receiver Rx pin and a transceiver Tx pin. The Rx pin does not need to be used as we will not be sending any data to the GPS design module. Hence the only 3 pin outs that are necessary are the VCC, GND, and Tx pin.

Interfacing with the MSP430 microcontroller is simple. The TX pin on the GPS module must be connected to an analog input Rx pin on the MSP430. In order to properly use the module, the antenna must be faced towards open sky so that it can be in range of satellites. The minimum must be 3 satellites for accurate

readings of coordinates. An LED is used on the module for dictation of whether the module is searching for satellites or if enough satellites are found. No blinking dictates that there is nor satellites in range. One second interval blinking dictates that there are enough satellites for an accurate reading.

For testing purposes and for a possible final design implementation, hardware serial mode was used on the MSP430 in order to use the pinout 1.1 as a receiver pin. The software design side of the GPS design process will require to understand UART communication and how serial data is transmitted. Serial Data is transmitted and the MSP430 will receive data at 9600 baud rate. Hence, once all interfacing is done, the serial window can be opened to view the data that is being sent by the GPS. The data being received from the module is NMEA sentences or National Marine Electronics Association. This is a standard format for all GPS serial messages. The important serial sentence for our design is the \$GPRMC sentence (Global Positioning Recommended Minimum Coordinates). This sentence displays the time, date, latitude, longitude, altitude, and velocity.

For user interface simplicity, it is important to translate these sentences into readable outputs on the display. This will be seen in a future section that shows initial testing of the GPS module. A block diagram of the design and interface of the GPS module with the microcontroller along with the voltage regulator can be seen below.

Figure 29: GPS Interface Block Diagram

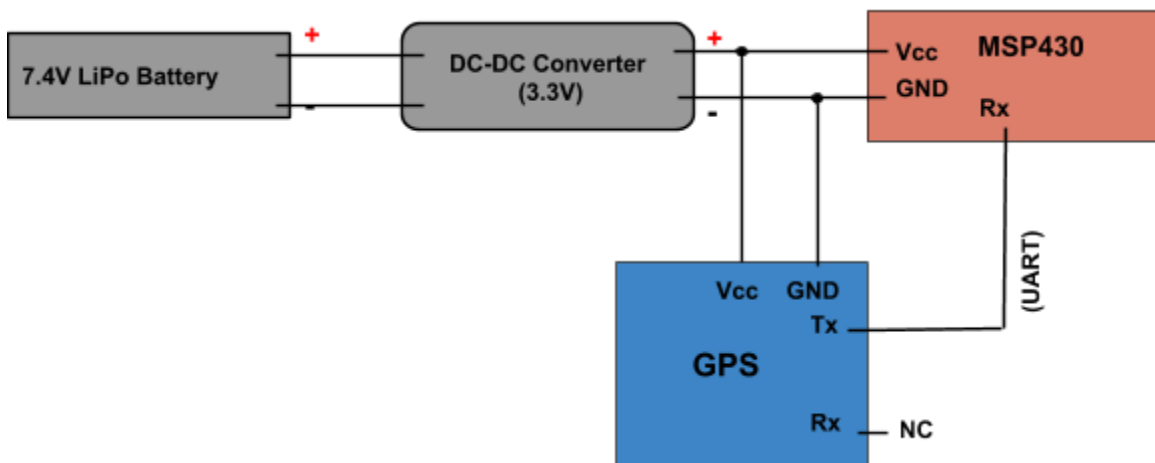

## 5.6 Depth Sensor Design and Integration

### 5.6.1 Microcontroller Integration

The piezo SM111 we concluded should be controlled by a TI microcontroller. (For details on TI microcontrollers see section 2.2.2) The details of the TI

microcontroller and its specs data and full connections are covered in detail in a future section. In this section we are simply covering the specific requirements and connection from the TI microcontroller to our transducer Piezo material.

Raspberry Pis can produce audio simply attaching a HDMI monitor with built in speakers or attaching amplified speakers to its audio port. However this is not the route we opted for because this is not compact, it's not light weight and it also is not energy efficient. The ability to be energy efficient is important because the hardware to prove large amounts of power wouldn't fit in our small boat.

The SM11 transducer will have a soldered wire connected to it, one leading to the microcontroller the other to the oscillator and power amplifier. The microcontroller will have a pin intended for the transducer to attach to so it can transmit its data so the microcontroller can compute it. The other connection will lead directly from the oscillator and power amplifier which is where the transducer gets its signal and amplitude. A full block diagram is provided below for more details on the connections of this device to the microcontroller

*Figure 30: Depth Sensor Schematic Diagram*

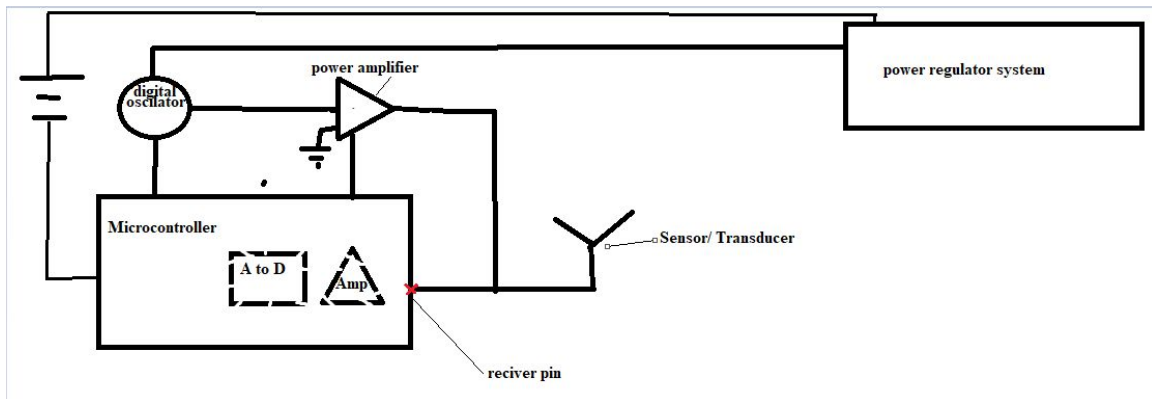

## 5.6.2 Oscillation and Power Amplification

As depicted in the above diagram the transducer will be wired to an oscillator and power amplifier. These both have unique purposes in this project, the oscillator is needed to provide the frequency required by the SM111. In this case the resonance frequency is 215 kHz, this part will be attached to our PCB and provide this signal for our transducer. The power amplifier is to take the voltage from our microcontroller and amplify it to the needed voltage to travel the distance we need. The voltage is essentially the amplitude of the signal and the larger it is the further our signal can travel. This amount that is needed can be calculated by taking into account the attenuation absorption and the reflection efficiency coefficient. Concrete has approximately a 95% reflection efficiency

losing only 5 percent of our total dB. The absorption in the water we will be testing in is approximately 9 dB, for roughly a range of 20 ft we went with a 150 V power amplifier.

## **5.7 Raspberry Pi and Camera Design**

The raspberry pi by default is already a sophisticated design and board with many functions. Hence, the design for this section will be very quick and simple. However, software design for image processing with the raspberry pi and interfacing with the camera is more complex. Software design of the ARV is explained in a later section in this report.

The raspberry pi requires a constant 5.1V as a power on requirement. Since the vehicle is a mobile vehicle, a battery pack must be used that is rechargeable and at the same time similar to the overall boat battery. The similarity is important because the charger should be able to charge both batteries and the user should only need one charger type and not multiple for each device in the system. This takes care of ease of use of the design requirement and a simpler user instruction manual. As was discussed in a previous section, the battery chosen for the raspberry pi was the 3.7V LiPo battery pack that comes with a circuit protection board in case of spontaneous turn off from a dead battery or a peak in input current during turn on of the battery pack. The circuit protection board interfaces with the raspberry pi through a USB to USBC connector. For space requirements of our design, a six inch cable must be used in order to fit inside the boat and save space for other components.

The raspberry pi board itself requires no additional hardware designing, however, software design will be required and discussed in a later section. The last interface with hardware that is needed in our design is the camera module with the raspberry pi. The camera module is connected through a flex cable and is directly connected to a connector that is already pre installed on the raspberry pi board. The camera is easily enabled and can now start streaming wirelessly after the correct software is implemented.

The block diagram for the power to raspberry pi to camera module can be seen below for a better hardware understanding.

Figure 31: Raspberry Pi Interface Design Block Diagram

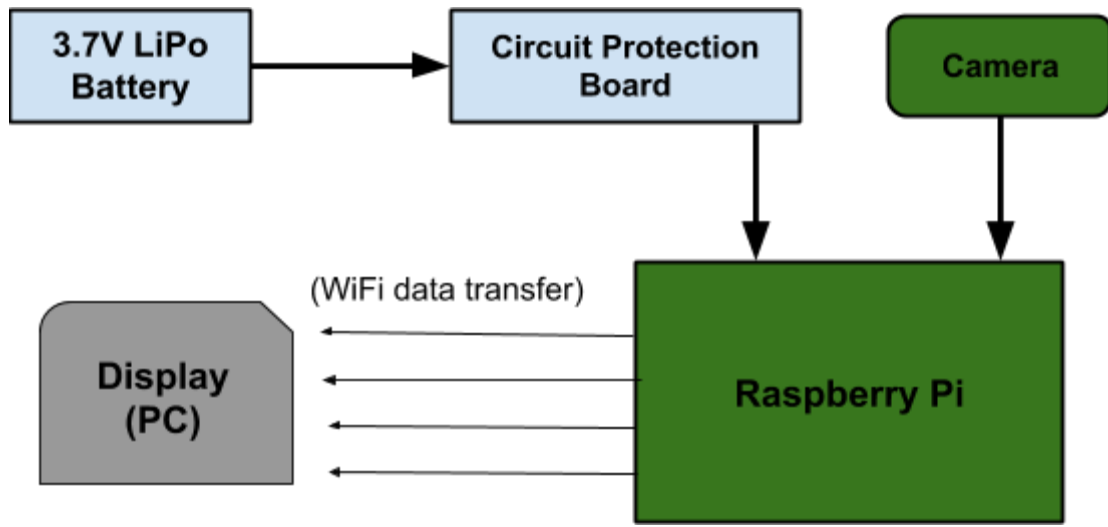

## 5.8 Wifi Module Design

### 5.8.1 ESP8266 Wi-Fi Module

The ESP8266 is a low-cost Wi-Fi microchip compatible with microcontrollers that we will be using to interface with the MSP430 through Wi-Fi. It is manufactured by Espressif Systems in China. Due to its microcontroller compatibility and its low cost, it is perfect to fulfill the role of transmitting the sensor and GPS data to arvsd.com through Wi-Fi, as well as taking in the navigation inputs from the user from the same website. How the ESP8266 will be connected to the MSP430 can be seen in the figure below.

Figure 32: Wifi Module Interface Design

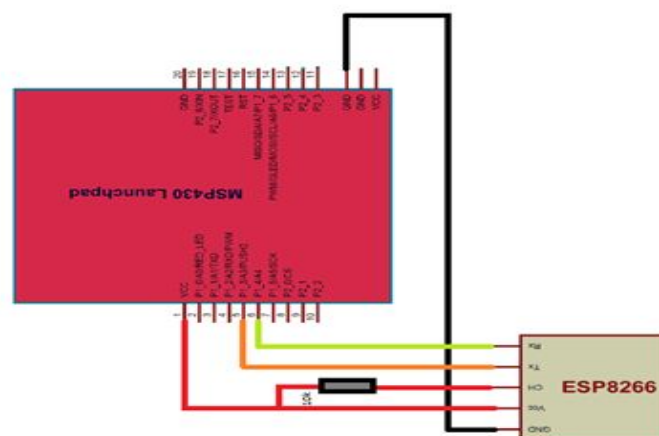



## 5.9 Component Breadboard Testing

### 5.9.1 Overview

All essential components that will be added to the boat were ordered and tested to ensure functionality. This is done to ensure components will interact and behave as intended. It is crucial to verify that components operate as designed in their individual roles, prior to integrating them into an overall system. Because if one component fails you can many times be thrown into a scenario of falling dominos.

A regulator fails causing a surge of voltage that then burns out an expensive component. So each component of our system needs to be individually tested and observed before building the project to avoid these scenarios. Each must be looked at first for obvious exterior damage that could have happened when manufactured or when shipped. Once this is done then the component will be tested using minimal amounts of other equipment before then being tested with our other components. All major components were bought by suppliers that can be seen in the suppliers table in chapter 7. All tests were performed for functionality and test results will be displayed in figures throughout the following sections for each major component. The image below shows all major component parts that were purchased for testing.

Figure 33: All Major Components for Testing

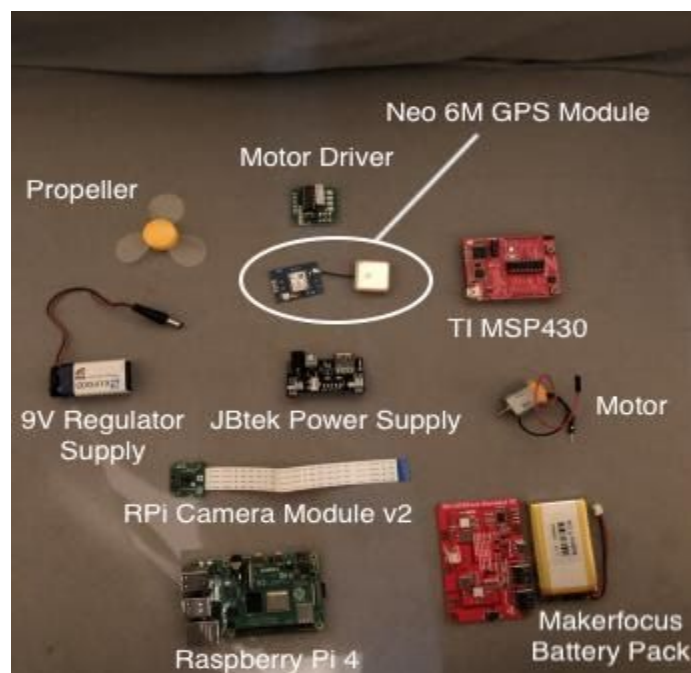

## 5.9.2 JBtek Power Supply and Motor Driver

The power supply module provides 3.3V and 5V from a 9V battery supply. The battery was only used as a testing power source because the LiPo battery will only arrive with the Boat purchase. The boat will not arrive until the 30th of July. Hence, this specific motor test uses a simple 9V battery. This is acceptable because these tests are only functional tests to make sure no equipment is faulty. It was used to test the motor and propeller combination, the battery is what will be attached to this power supply. The motor will draw our desired voltage from the 9 V through the power supply and use its torque to then turn the propeller. Our desired voltage for our initial test was the 5V. Each component worked as intended and the test was a success.

The motor driver was also an important step in this test as it provides us the ability to test the controllability of the motor. Interfacing with the MSP430 was necessary and can be seen by the connector on the motor driver hanging on the right side of the picture. The image below shows the propeller in motion, attached to the motor. The motor is then powered by the power supply and controlled by the motor driver through an interface and communication with the MSP430.

Figure 34: Power Supply, Motor Driver, and Propeller Test

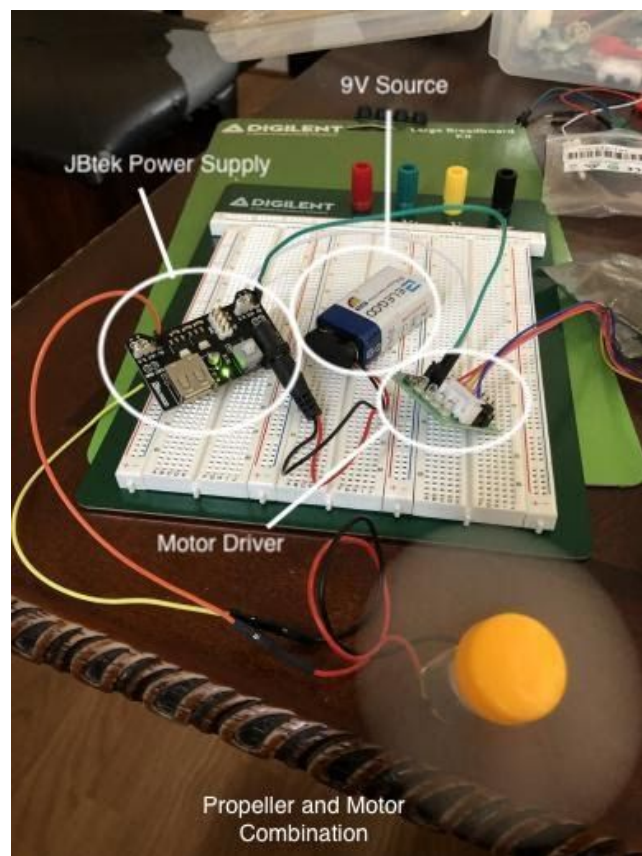

### 5.9.3 Makerfocus Raspberry Pi Battery Pack Test

The objective in testing the battery pack was to ensure a consistent and safe voltage being delivered to the Pi, as well as a quick insight into the battery life of the pack. The microcontroller was successfully powered as can be seen in the picture through a USB to USBC cable. A 6 inch cable was used in order to fit the size requirement for the boat.

This allows us to save room for other components.. The 75% battery life indicator LED was illuminated out of the box, and remained illuminated throughout the testing procedures. This test provided us with information on how long the 3.7V LiPo battery will last as the indicator had percentage markings for battery drainage. After a long test with the battery still at 75% capacity, it pointed towards a promising battery life of the overall raspberry pi design.

Although we used up nearly half the battery life during our testing procedure it still shows very promising amounts of extended life for all our uses. Because we had it on and running for almost a half hour and it wasn't initially charged to 100 percent the battery life will exceed an hour based on our initial testing which should be more then we will need for our system.

The next set of testing that will be performed with the raspberry pi board will be for image processing. The correct commands will be set up and different images of human faces will be remembered by the raspberry pi for object detection purposes. We will then feed this video onto a display to make sure the raspberry pi can detect faces accurately. We will also begin testing the live video stream of the raspberry pi using the built in wifi. We will be testing both the VLC and creating an IP address for video to be sent.

The purpose of the extra board in between the battery and raspberry pi board is for circuit protection caused by peak currents or faulty power losses. This can be caused by a loss in battery power and shutdown the raspberry pi unexpectedly. Hence, it was important to test whether the circuit protector board did its job correctly. The LiPo battery was disconnected while the Pi board was still in use to test if a failure would arise. However, the circuit protection board did its job successfully.

The below image shows the Makerfocus battery pack test powering on the Raspberry Pi. It can be seen that the battery only has one output power connection. Hence, it must be charged using the same ports which causes a slight unfriendly interface for our users.

Figure 35: Battery Pack Testing



### 5.9.5 Raspberry Pi Camera Module v2 Testing

The objective of testing the camera module was to obtain a quality image and verify the live feed capabilities of the camera and board. The Raspberry Pi has a thin port specifically for the camera module, and the connection is made via the camera's 15 way ribbon cable. The command window of the Raspberry Pi is used to download and install the latest kernel, GPU firmware, and applications, via the following commands.

```
sudo apt update
sudo apt full-upgrade
sudo raspi-config
```

The Pi is rebooted. Upon restart, the following command will feed a five second camera feed to the monitor, and ends with a screenshot that saves to the Pi.

```
raspistill -v -o test.jpg
```

The five second preview is suitable to confirm basic operation, but a constant live feed is more desirable. For this the following command is used, where the `-t 0` is what tells the camera to live stream to the monitor until told to stop, i.e. forever.

```
raspivid -t 0
```

This allowed us to observe the camera feed quality and response time. We were very pleased with the clarity, which will prove crucial in object detection in a dynamic environment. This test was done in a wired environment for video quality testing and functionality testing. A wireless test is not needed in the beginning stage because if it works wired then sending a video stream via wifi will not affect functionality of the camera. Since the quality is high definition, we do expect to see a degrade in quality over wireless communication. However, it will be very minimal since the quality is already in high definition.

The image below shows the live feed obtained displayed to the monitor that the Raspberry Pi was running on.

Figure 36: Camera Module v2 Test

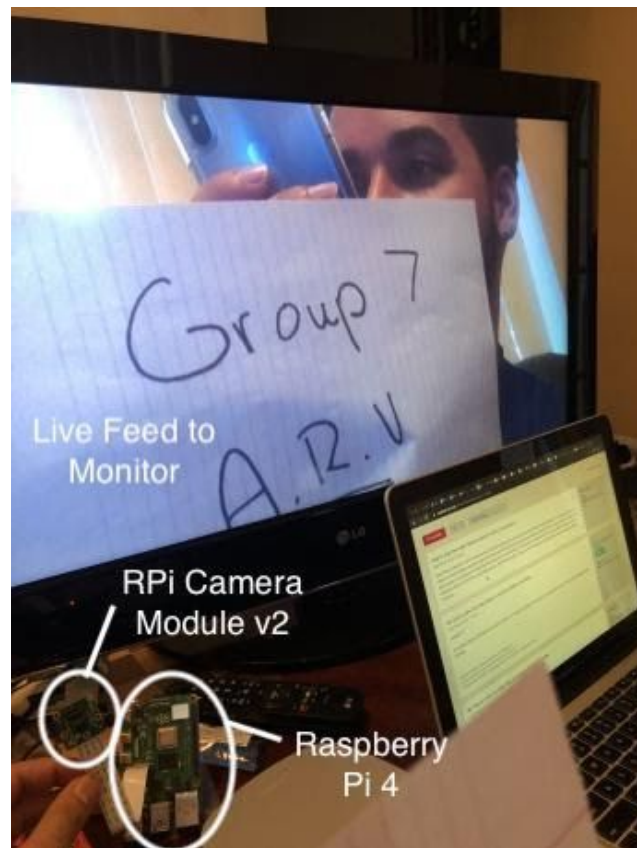

## 5.9.6 GPS Testing

GPS testing is crucial for our design implementation because it is one of the most important components on our system. It provides us with coordinates at all times while the boat is in use and will provide an exact location when the rescue vehicle detects a person in the water. As was previously discussed in the design section of the GPS module, the MSP430 interfaces with the module through serial communication and is connected to the Tx (transceiver) pin of the GPS module.

The antenna for satellite discovery is attached with a mini coax connector and is ready to use by default from the U-Blox chip on the GPS board. The first test that was run on the module was a power test to make sure the module turns on and is ready to communicate. As soon as power was provided, the LeD started blinking which told us that the GPS was in range of satellites and was ready to send data over to the MSP430.

A functional test picture was taken and can be seen in the figure below for more detail. Note that the GPS module is receiving power from the MSP430 board. The board outputs 5V and can be directly connected to the module without TTL conversion to 3.3V because the GPS board has an on board regulator that allows up to 5V on the Vcc pin. However, during system testing, the module will be powered by the 3.3V DC-DC converter. For testing purposes 5V power from the TI board was satisfactory.

Figure 37: GPS Module Testing

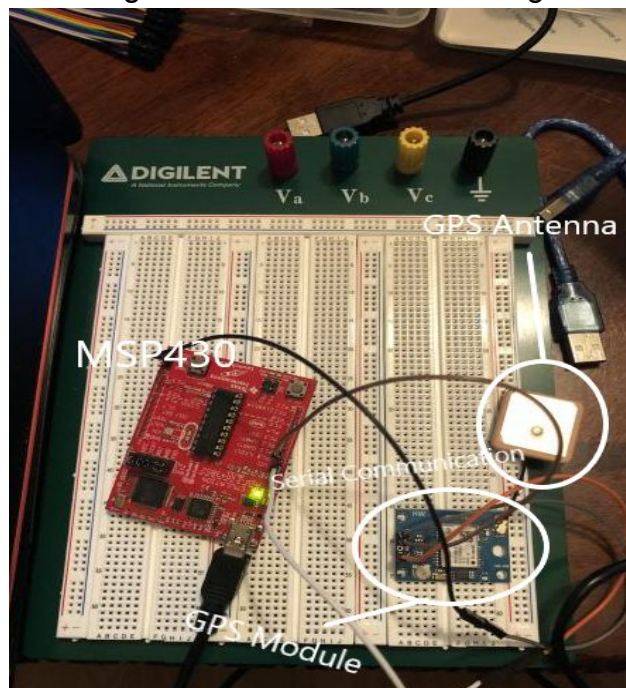

Once the power testing was complete for the GPS module, one lat test was required for functionality. A test for displaying coordinates of our current location was needed to make sure the module was outputting accurate information. Hence, it was necessary to write code that will help translate the serial data being delivered by the GPS module to a serial window. As discussed in the design section, the GPS data is sent over in NMEA messages. These messages can then be decoded in the software to display what the user wants.

For testing purposes, the Longitude, Latitude, Altitude, and Time was displayed in a serial window. The final output of the test can be seen in the figure below. It is important to note that the coordinates displayed are accurate and were confirmed using google maps. This test was performed in doors and provided accurate results. Hence, there should be no problem with establishing a connection to satellites in the open sky when a user runs the ARV.

Figure 38: GPS Coordinates sent from Module testing

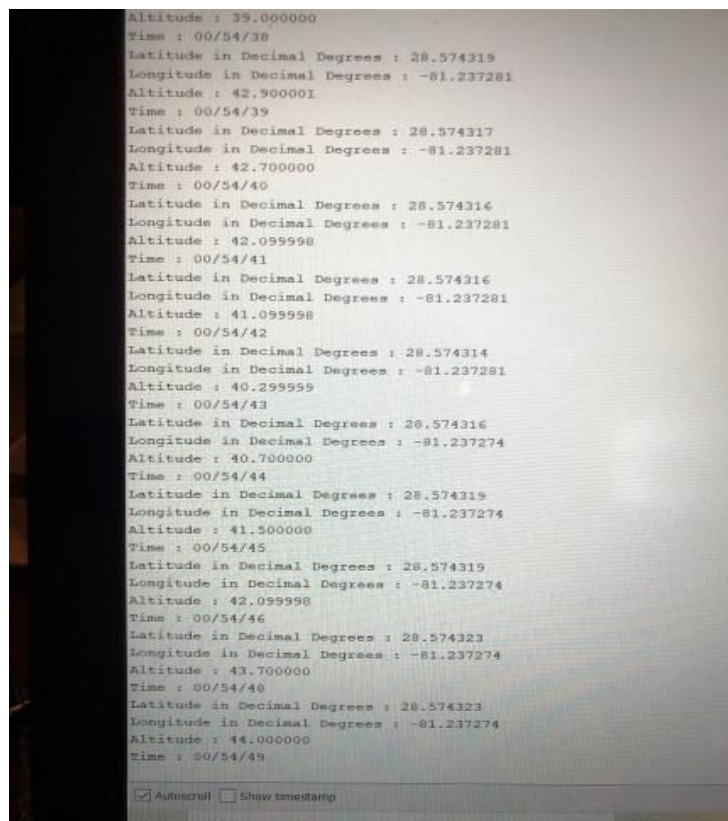

```
Altitude : 39.000000
Time : 00/54/38
Latitude in Decimal Degrees : 28.574319
Longitude in Decimal Degrees : -81.237281
Altitude : 42.900001
Time : 00/54/39
Latitude in Decimal Degrees : 28.574317
Longitude in Decimal Degrees : -81.237281
Altitude : 42.700000
Time : 00/54/40
Latitude in Decimal Degrees : 28.574316
Longitude in Decimal Degrees : -81.237281
Altitude : 42.059998
Time : 00/54/41
Latitude in Decimal Degrees : 28.574316
Longitude in Decimal Degrees : -81.237281
Altitude : 41.099998
Time : 00/54/42
Latitude in Decimal Degrees : 28.574314
Longitude in Decimal Degrees : -81.237281
Altitude : 40.299999
Time : 00/54/43
Latitude in Decimal Degrees : 28.574316
Longitude in Decimal Degrees : -81.237274
Altitude : 40.700000
Time : 00/54/44
Latitude in Decimal Degrees : 28.574315
Longitude in Decimal Degrees : -81.237274
Altitude : 41.500000
Time : 00/54/45
Latitude in Decimal Degrees : 28.574319
Longitude in Decimal Degrees : -81.237274
Altitude : 42.099998
Time : 00/54/46
Latitude in Decimal Degrees : 28.574323
Longitude in Decimal Degrees : -81.237274
Altitude : 43.700000
Time : 00/54/48
Latitude in Decimal Degrees : 28.574323
Longitude in Decimal Degrees : -81.237274
Altitude : 44.000000
Time : 00/54/49
```

Autocroll  Show timestamp

## 5.10 Overall Schematic

We need to design an overall PCB and then have it printed. A PCB is a printed circuit board, they are used in many different respects but in our case this will be

the central connection of our design. All the sensors except for the camera will be run through this PCB as well as all the batteries and power regulators.

Eagle software is a software for designing schematics for printing onto a basic circuit board. EAGLE stands for Easily Applicable Graphical Layout Editor and is developed by CadSoft Computer. This software was chosen because of its user friendly interface and because it is a free software to use. Footprints and schematics for designs can be found for Eagle software for almost every component. It also has the capability of creating a personalized footprint.

Figure 39: Eagle Software



When using this software you will need to open up eagle and go under the file tab and press new schematic. You will be opened to a blank graph area, on your right will be a toolbar that you can choose from for many different uses. For moving components rotating them or deleting them. In many ways the schematic interface is visually very similar to many other schematic softwares like multisim and LT spice.

Each component when placed has its individual symbol that you are familiar with in electrical engineering work. Classic resistor symbol op amp ect so it should be easily recognizable. Designing the schematic for the voltage regulators was done on paper and simply needed to be added to the schematic digitally, this was done relatively easily. Each design had to be created in a digital schematic file and then all of these had to be transferred to our board diagram.

We need to add a microcontroller to our PCB to integrate the data that the sensors will be feeding into the board. There is no footprint or part for our schematic. This is a common issue that can be experienced however the eagle library while huge is always able to have components added to there library. You're able to go onto texas instruments website and find the specific microcontroller you're looking for and then also it will have a schematic part file on there. This will be listed as a .BTX file, this is not compatible for the eagle library so we will need to use a third party converter.



In junior design we used ultra librarian, so this will be the third party we will use again. Ultra librarian is a third party CAD and schematic library. We are able to take the schematic footprint we have from the texas instruments library and search it into the ultra librarian. Once we've done this the file will appear in ultralibray and you just select the eagle format for the texas instruments part. After you've added it to your library in eagle then it is easily added to your schematic system and makes any connections you would like to.

Figure 40: Component Footprint Software



Once the schematics are finished we would need to go to file and click convert to board. This will take the full schematic that was created and will allow us to create the outline of our board. This will require us to obtain the dimensions as well as the placement of all the different footprints and component placements that were created in the schematic. That is why it is important to only place components with footprints attached to it. In order to achieve our design requirements and meet the dimension specifications that was discussed in chapter 2, our PCB should be designed using a square shape. This will allow us to conserve space packing in all the footprints from the components as systematically as possible so we can conserve space.

Once they all are in we will be able to start wiring the board. This is the digital process of putting the grooves and etchings in the board. The wiring one in the schematic section of eagle will be transferred over to the board section and is already connected to the components. Hence, we must place the components on the board correctly so that no wires cross over one another.

Some important things we must consider when wiring the board is that a 90 degree angle is considered the wrong thing to do when designing a PCB. Hence, we will be using 45 degree angles and it will be shown in the PCB figure in a later section. It is important to keep consistency when making the connections because we can't overlap wires because the current will then mix ruining any accuracy or consistency in your connections.

Also keeping the wire paths without any 90 degree angles creates a much more efficient circuit. It is possible to have 90 degree angles if it is the only way but with smart component placement this should be fully avoidable as it is highly advised to avoid it. The wiring needs to be rigorously checked because if there is

a connection error the PCB will be ruined when it's printed. This must be avoided at all costs due to our time constraint and the deadline for having our full design built. Hence, it is important to give enough time for testing and potentially re modeling the PCB design.

The board will be checked for footprints layers and wiring then it'll be shipped out to the provider and the PCB will be printed and mailed to us. We plan on ordering copies of the board in case one is flawed or we break one.

## 5.10.1 Complete Schematic

An overall schematic was accomplished using the eagle software. The first portion of the schematic will show a DC-DC converter that was designed using webench. However, the design needed to be placed in the eagle software so that we can include it in our PCB. It is important to note that for the entirety of the design all components such as resistors, capacitors and inductors are chosen to be 0603 or 0805. This dimension was chosen because they will be big enough for an easy soldering job on the PCB.

The left side of the regulator design shown in the schematic contains soldering pads for the input power that will be provided by the LiPo battery. We will directly solder the wires from the battery to the pads on the PCB. Capacitors are then used to filter out noise and any unwanted signals going into the input of the regulator. The output is then 3.3V and can be seen connected with a Vcc arrow on the schematic to pinouts on the microcontroller.

The MSP board that was chosen to integrate in our design and included on our PCB is the MSP430F5529. This was chosen because it contains various digital output pins with pulse width modulation. It also has a lot of transceiver and receiver pins that are needed to interface with all of our sensors. It would not be plausible to purchase a G2 MSP430 because there are not enough pinouts for our design. There will be 3 total sensors interfaced with the msp430.

The first and most important is the motor driver. This driver uses 6 pin outs for interfacing with the motors. The first two are enable lines that enable the motor to go a certain speed. This can be seen connected to a digital pin out in the schematic below. Pulse width modulation will be used on these lines for controlling the speed at which the motors operate.

The next 4 pins are input pins that control each motor on and off state. This allows us to turn the vehicle when we want. Each of these 6 lines will be connected to pin headers on the board. Wires will be connected from the pin headers to the motor driver. Headers are used for ease of use and no need for soldering. This allows for modifications of the design.

A receiver analog pin is used to interface with the GPS module as seen from the schematic. This will be specifically used to read data that is being transmitted from the GPS module. There is no other interfacing needed except for a 3.3V turn on that will also be provided as an output on the pin header.

A 3.3V line will be connected from the output of the voltage regulator to two pin headers. Our design requires two of the pin headers to be 3.3V because two of our sensors require that much voltage for turn on. A GND pin is also necessary in the pin header to be able to connect to both sensors.

In order to code the microcontroller, there must be some type of interface with a USB so that the computer can send data to the microcontroller. In order to provide this interface, we will be using a launch board from TI that already has this USB interface. The only necessary adjustments needed is to remove the jumpers on the launch board and connect the correct lines to the pin headers on our PCB. The schematic below shows these connections as Reset, Test, RXD, and TXD.

There are two digital VCC pins that need 3.3V fprp functionality and must be connected with a capacitor. The analog Vcc pin is also connected to 3.3V power and must have a capacitor between power and ground. The pinouts Xin and Xout on the microcontroller require a crystal resonator that has frequency of 32.768kHz. This must be included in the design for clocking purposes of the microcontroller. Future lines and components will be added in the overall schematic due to change of design or test results. Hence, it is important that we have extra pins available in case anything is added.

It is important to note that this will not be the final design of the schematic because during senior design 2, a lot of things might change based on testing the overall design. Some suppliers could be out of stock of certain parts, which can cause a change in the schematic as well. More pin headers will be used if we decide to integrate the motor driver into the PCB.

The H-bridge on the motor driver can be integrated on the pcb so there would be one less module in our vehicle. This will result in an addition to one more regulator because the enables for the drivers require a 5V input. The overall schematic can be viewed in the figure below

Figure 41: Overall Schematic using Eagle

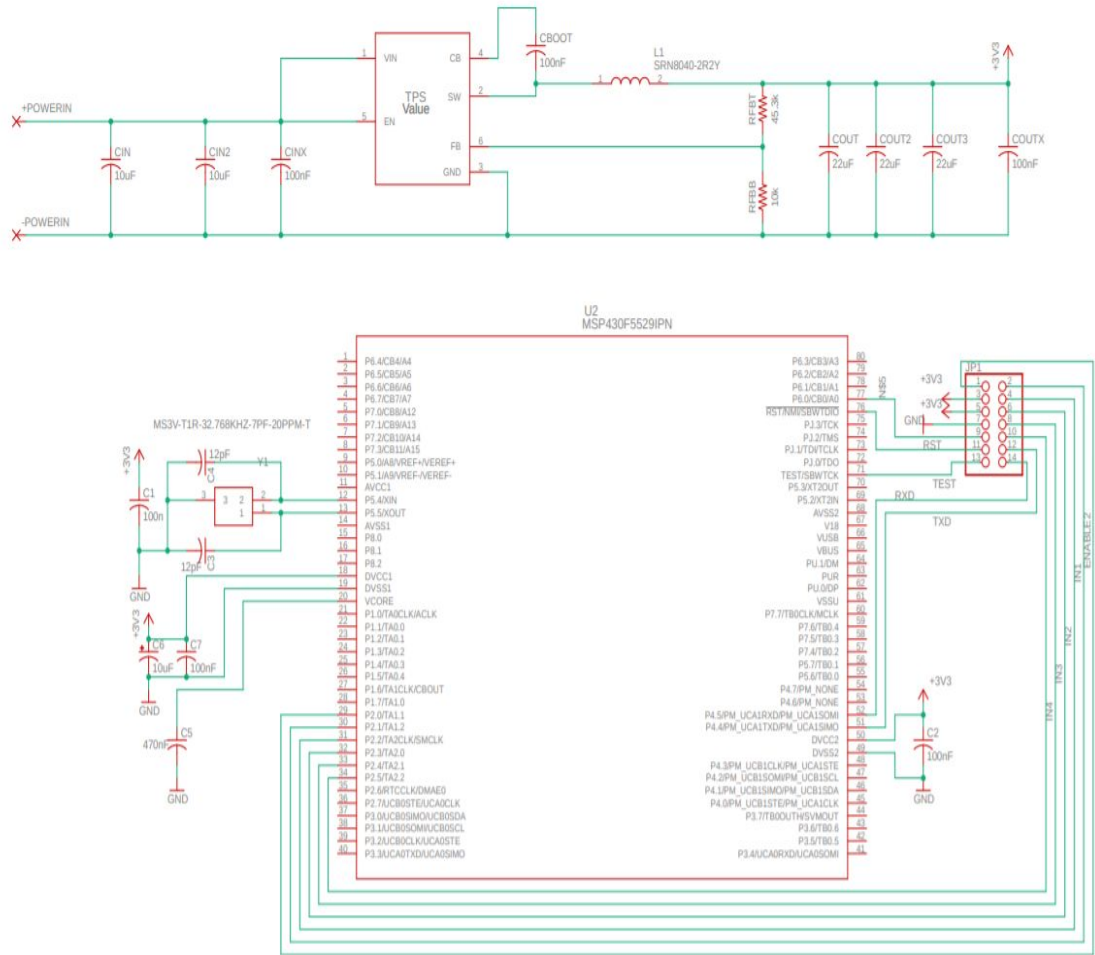

## 5.11 Software Design and Flowchart

### 5.11.1 Software Design

While the Automated Rescue Vehicle (A.R.V.) will require a good amount of knowledge in terms of hardware design in the production phase. The bulk of the production will be focused on the software design. Applying concepts, such as image processing, vehicle automation, and web development, will prove to have a challenging learning curve. This is especially true when you consider that the group is made up of three electrical engineers and one computer engineer. The only person in the group with a solid foundation on software is the computer engineer.

## 5.11.2 Development Approach

In the software development stage of the production phase, we will be implementing what's known as the Agile software development approach. The Agile software development approach simplifies production by putting emphasis on self-organization as well as division of teams based on functional expertise. It also pushes for more adaptive planning, such that there is room for overcoming any unexpected hurdles that may come by during the production process. This combination of proper self-organization, specialized teams, and well-planned flexibility proves to be an excellent practice for the sake of delivering on a project.

One of the most, if not the most, beneficial aspects of using the Agile development method is its iterative nature. With Agile, the production phase gets divided into small increments or iterations known as sprints. These sprints are essentially short frames of time in which all specialized teams perform to complete a working product by the end of the frame. While the working product may not necessarily be a completed product, the specialized team may access the product in its current form and decide what should be completed in the following sprint. Subsequent sprints will build upon the original working product until, eventually, a completed product is reached.

This method takes on production with a more evolutionary approach, in that the result of each sprint is essentially a new and improved child of the respective sprint's predecessor. Consequently, this results in less overall risk of having an unfinished product. Let's consider a more traditional, non-Agile approach, where instead of setting short-term goals for the project, a team decides that they will not produce a working product until the final stage of production has been completed with all the intended, desired features implemented. This approach leaves little to no room for adaptation, and if the team were to fall behind it enables the possibility for a very buggy, if not completely non-functional, product.

When large issues arise in production, the Agile development process allows for the team to adapt by enabling them to properly address complications that arose during a sprint and take the appropriate measures to resolve these known complications. The solutions to such complications may be reached within the next sprint or throughout multiple subsequent sprints. In order to ensure that issues are properly addressed, it is common practice to hold daily stand-up meetings, sometimes referred to as scrums.

During these daily stand-up meetings, the idea is for the team members to communicate what they worked on the previous day as well as what they plan to do that day and any issues they may have come across or potentially need help to fix or overcome. To take full advantage of the excellent time management provided by the Agile development process, communication plays a very important role. Taking this into consideration, typically in the Agile development

process, it is recommended that teams meet face-to-face. With face-to-face interactions, there is oftentimes less chance for miscommunication, which improves productivity as well as potentially boosting morale due to the fact that being situated together helps to better establish identity as a team.

In our situation, due to COVID-19, it is unlikely for us to be able to regularly hold meetings in-person, but we will try to compensate with virtual meetings and persistent group chats. Although we are facing unfortunate circumstances, we already have a general idea of how we would like to organize our sprints. We intend to organize the sprints as follows:

Table 27: Sprints and Products

Sprints	Product
1 <sup>st</sup> Sprint	RC boat built (manual operation functional)
2 <sup>nd</sup> Sprint	Automation implemented
3 <sup>rd</sup> Sprint	Camera streaming implemented
4 <sup>th</sup> Sprint	Image processing implemented

### 5.11.3 Programming Tools

In software development, there are several tools to make use of in order to ensure a more streamlined production period. These tools make for a much faster and simpler development process. The specific tools we will be making use of will be explored more in further sections.

#### 5.11.3.1 Integrated Development Environment

An integrated development environment, also known as an IDE, is a software application that functions as a comprehensive collection of tools computer programmers utilize during software development. IDEs typically consist of a code editor, code compiler, and debugger. As the Automated Rescue Vehicle (A.R.V.) will have both an MSP430 and a Raspberry Pi that won't be communicating with each other, it's possible that we will be interfacing whip the chips using different programming languages, and thus, different IDEs. At the

moment, we intend to use Energia IDE for the MSP430 and Arduino IDE for the Raspberry Pi.

Energia IDE is a cross-platform electronics prototyping platform designed with the intention of bringing the Arduino framework to the Texas Instruments MSP430. The benefit of using Arduino software, along with the fact that the IDE is open source, is the vast collection of drivers available to plug in and immediately utilize. With so many resources available, Energia IDE is perfect for controlling a variety of sensors, motors, and other modules through a microcontroller.

Along with the previously mentioned vast collection of drivers, there's an abundance of pre-existing example code for Arduino that provide an excellent framework for how to code with Arduino language as no one in the group has any prior experience with the language. Rather than constantly having to research how unfamiliar functions operate as well as being constantly unsure of proper syntax, these large sets of sample code provide examples of such functions in use as well as examples of proper syntax.

In Energia IDE, projects are referred to as sketches. Sketches are formatted in such a way, where each program has both a main function and a setup function. Main functions are commonplace in most programs and programming languages, but the setup function is something relatively exclusive to the Arduino framework. The setup function's purpose is to run once at start-up or on reset to initialize everything.

As mentioned previously, the Arduino framework uses the Arduino programming language, which is based on the C and C++ programming languages. Dariel Tenf has a large amount of experience with C and all other members have at the very least taken an entry level class.

As mentioned previously, we are planning on using the Arduino framework on the Raspberry Pi as well, but rather than using the Energia IDE, we intend to use the Arduino IDE. What sets the two IDEs apart is essentially their purpose. Energia IDE is simply used to bring the Arduino framework to MSP430 Launchpads. Because the Raspberry Pi is not an MSP430 Launchpad, we cannot use Energia IDE for it.

### **5.11.3.2 Version Control System**

Version control goes by many names, such as revision control, source control, or source code management, but regardless of the name used, it plays as a vital component of software configuration management. Version control systems are responsible for managing revisions to computer programs, or more generally, collections of data. It identifies changes by labelling each revision with usually a number or some string of characters. This is important because it is of the nature

of humans to make mistakes, and especially in computer programming, mistakes can result in the loss of a great amount of progress. A small mistake in code can render the entire program unable to compile and run, therefore it is in the best interest of the programmer or programmers to keep track of their revisions, so that if such a mistake were to ever occur, the programmer has the ability to revert to a previous revision rather than starting from square one.

Additionally, version control systems play an even more important role in collaboration. It is extremely common that programmers often do not have a full understanding of the logic behind another programmer's code by simply reading over the code once. Because of this, it is considered good practice to have well-commented code, but when programmers are collaborating on a project, there can be collisions in logic or one of the team members may accidentally submit buggy code.

In such an event, version control plays a great role, because revisions are typically given a timestamp, which marks what time a change was made as well as who made the change. This allows the team to access at which revision the project began to have issues as well as who was responsible so they may make the necessary corrections or the team can collaborate to take on the newfound issue with the assistance of the programmer who initially wrote the code.

There are plenty of available options in terms of which version control systems to pick out of the several. These options include GitHub, Bitbucket, Perforce, and etcetera. It is uncertain what platform will be used at the moment due to several factors being at play. Darrel has some experience using Perforce, but no matter which is picked, there will definitely be a strict learning curve as, unfortunately, most, if not all, version control systems have been notorious for their lack of user-friendliness. At the moment, we are leaning towards Perforce and Bitbucket.

## **5.11.4 Sensors**

The depth sensor and the temperature sensor have very basic functions; simply collect data and report the arvsd.com. The logic for the software controlling both sensors can be seen below. The MSP430 will search and attempt to connect to a Wi-Fi network. Afterwards, the sensors will continuously report the data to arvsd.com every five seconds. The flowchart for the sensors can be seen in the figure below. Note how the logic is set up and how the system will continuously check if the connection is made and if data is being sent at an efficient rate. This is extremely important in our software design as this will help us debug or design a lot quicker during the build in senior design 2.



Figure 42: Sensor Software Flowchart

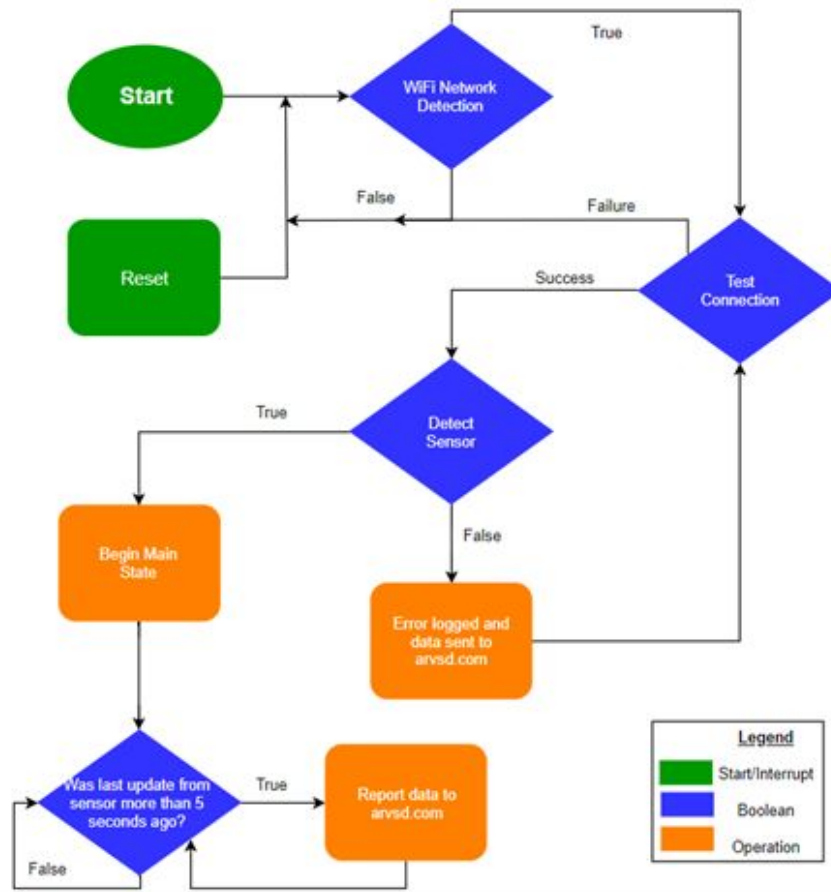

### 5.11.5 GPS Module

The GPS module has a slightly more complex task than the temperature and depth sensors. The logic for the GPS module can be seen below. The GPS module begins with essentially the same process as the temperature sensor and the depth sensor. The MSP430 will attempt to connect to Wi-Fi network, and if successful, the GPS will begin relaying data to arvsd.com every five seconds.

What makes the process different from that of the sensors is if the user wants to navigate to some desired coordinates, then that will create an interrupt where the MSP430 will need to continuously compare the desired coordinates with that of the GPS module's readings. This will allow the user to interface with the vehicles movements without needing to manually control the vehicle to the requested destination. Thus, this interface design will help our design meet marketing requirements that specify for ease of use and efficiency.

Figure 43: GPS Module Software Flowchart

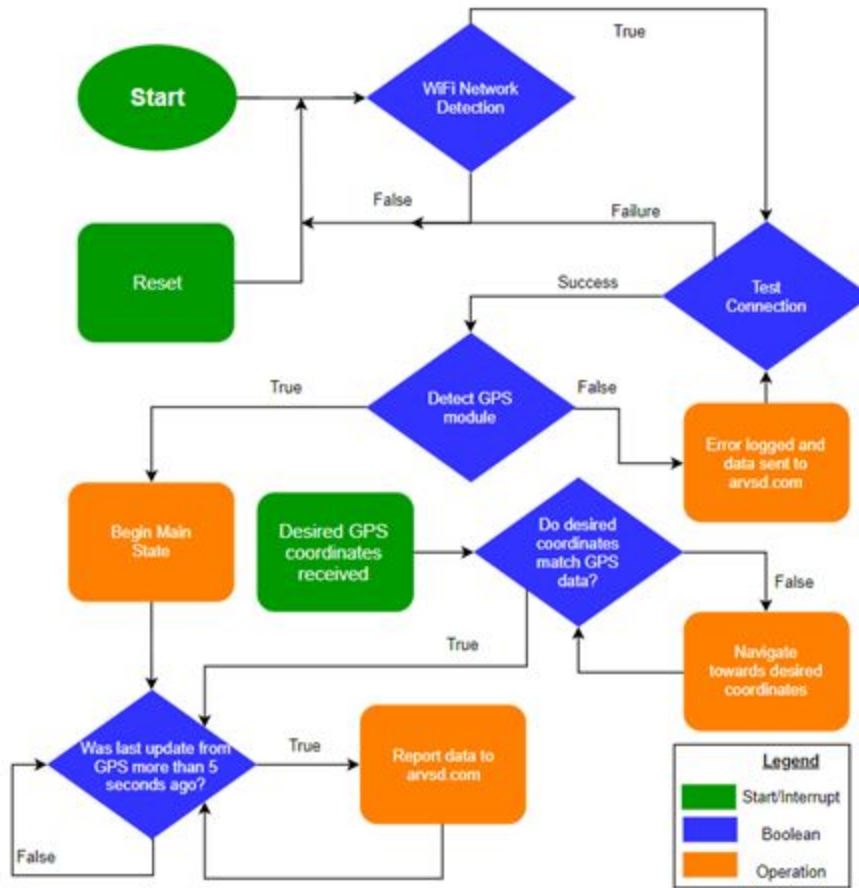

### 5.11.6 Camera

The camera is the most dissimilar in terms of logic during normal operation, although the beginning of the logic is practically the same in that the Raspberry Pi will begin by attempting to connect to the Wi-Fi. However, afterwards the Raspberry Pi will then begin streaming the video to arvsd.com. This will continue unless a desired object is caught on camera using image processing. At which point, an interrupt will strike, and the Raspberry Pi will send a string stating what the Raspberry Pi thought was caught on camera as well as an image of where the desired object is. The logic and flow chart can be seen in the figure below. Note how the raspberry pi is a separate chart that doesn't interact with the other sensors or microcontrollers. Although it is not interacting with one another the data will still be sent to the same place in the end as can be seen in the figure.

Figure 44: Camera Software Flowchart

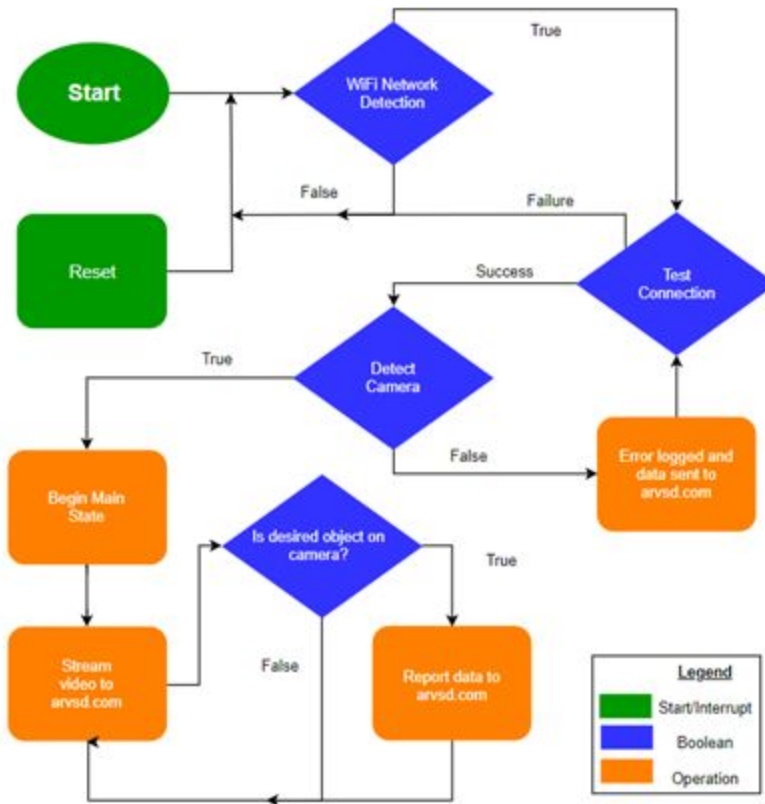

## 5.12 Streaming on VLC Media Player

Choosing a display option for streaming is only the first part of live video streaming. The second portion is understanding which platform to use for streaming the processed video. VLC Media Player is compatible with both the iphone and a laptop. It would be impossible to use it on the TFT LED Display, which is another reason why that option was not chosen.

VLC will only be an option for our users to use as an IP address can also be used for watching the video stream. However, the difference is that the VLC media player will only provide the stream of the image processing taking place and the IP address method will have all other sensor data included. Step for streaming on VLC with the Raspberry Pi can be seen below:

### Streaming Configuration

1. The most important step is to ensure that the camera module is configured and enabled using the Raspberry Pi Software Configuration Tool. This can be accessed by “sudo raspi-config”

2. Without VLC player installed on the raspberry pi, it will not know where to send the video because VLC media player must be connected on both platforms. Hence VLC Media player is installed using “sudo apt-get install vlc”.
3. Once VLC is installed, the video can be streamed by writing various commands to specify the width, height frames per second, and destination that the video is going to. Http must be specified in the code and the video must be flipped due to mirroring effect.
4. Lastly, it is important to know the IP address of the raspberry pi which can be found using “ifconfig”. The IP address of the raspberry pi is automatically set to dynamic, which means the IP address will change after every reboot. For more efficient use, the IP can be changed to static through methods that will be discussed in a future section.
5. Finally, VLC Media Player can be opened on either the Iphone or on a laptop. The stream can be seen by opening a network stream in the settings and filling out the IP address of the Raspberry Pi on the command window. The destination number that was established in the code must be written as well.

## 5.12.1 Streaming on Browser (http)

Streaming on a browser window is simple and is very similar to streaming on VLC. A positive of this method of streaming is that when streaming to a browser, a video window and sensor data can both be displayed on the same window. This makes it easier to view sensor data while watching the stream at the same time. Using this method can also benefit the video that is displayed as controls can be set up for the camera. Brightness settings, contrast and pictures can be taken while the video is streaming live. Steps for streaming on a browser can be seen below:

### Streaming Configuration

1. The same process of enabling the camera module must be done in this method. Github must be downloaded in order to run OpenCV code and scripts from github. A github clone must be done to copy the code install.
2. Once the install is complete on the raspberry Pi, all that's left to do is open up the video stream on the browser. This can be done by typing in the IP address of the Raspberry Pi on the url followed by the port number used and the subfolder.

Streaming on the Browser has much more potential for multiple data being displayed on a single page. This method poses various controls that can be used to adjust the video quality on the rescue vehicle compared to using the VLC media player which has no control options. The controls that are possible with this method include shut down and reboot of the Pi board, taking a time-lapse of full HD resolution videos and saving them and time stamping. Image resolution and frame rate can be adjusted for video quality.

## 5.13 Setting Up a Static IP Address

Assuming that Raspbian has already been installed and is running on our system, the first step is to connect the Raspberry Pi to a network that we will be using. Once connected the current IP address assigned to the board must be obtained as well as the Broadcast Range Number and the Subnet Mask. These values can all be obtained through the “ifconfig” command only when connected to a network. Next the following code must be run to gather information on the network router “sudo route -n”. This will give us the Gateway number and the Destination number needed to set up a static IP address.

Finally, we must open the configuration file for network settings by running the code “sudo nano /etc/network/interfaces”. This allows us to change the line of code that reads “dhcp” (Dynamic IP) and change it to “static”. Under this same line of code we can now write our chosen IP address followed by the netmask network number, broadcasting range, and gateway number that was previously recorded. Running “sudo reboot” will then restart the Raspberry Pi with the new Static IP address.

## 5.14 User Interface

As seen on the figure below, there is constant communication between the user and the embedded microcontrollers of the A.R.V. through the user interface. The camera for the A.R.V. is connected to the Raspberry Pi, which is responsible for the image processing capabilities of the vessel as well as streaming the video to “arvsv.com”. While the Raspberry Pi is responsible for the video component of the A.R.V., the MSP430 handles everything else, which includes data collection and navigation.

Due to the nature of the responsibilities of the Raspberry Pi, it’s unnecessary for the user to ever communicate with the aforementioned computer. The only data that is sent from the user goes directly to the MSP430. This data is simply navigation commands for the A.R.V. to follow. Additionally, while taking navigation inputs from the user, the MSP430 also sends the user the data taken from the sensors.

Figure 45: User Interface Block Diagram

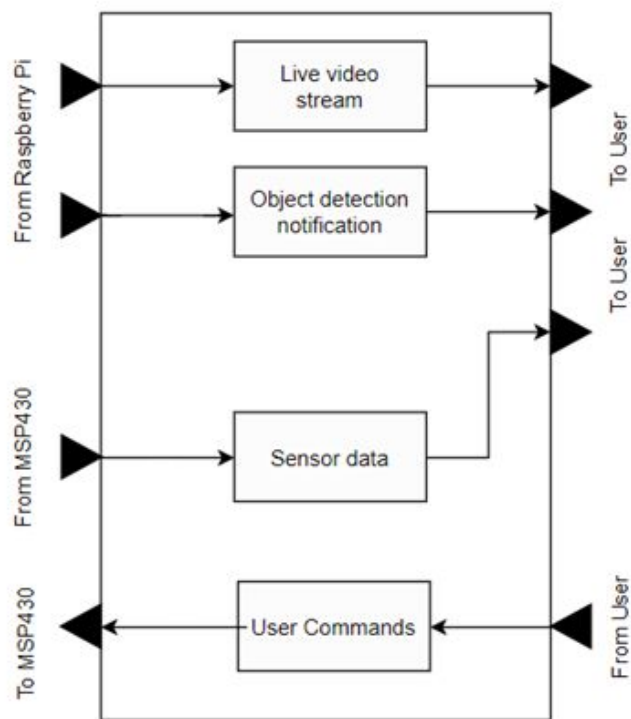

## 6.0 Integration, PCB, and System Testing

### 6.1 Overall Integration

In this section we will be discussing the prototype, PCB design and testing. The initial prototype of our system is represented graphically in the below diagram as well as discussed fully in sections 6.3 the intent was to have a firm understanding of a simple outline of our project and also have something for the reader to see to understand the end goal.

The PCB design is covered in a picture provided of our schematic. The PCB is converted from schematic to printed circuit board through eagle. (see section on eagle in chapter 5). PCB design is covered in 6.2 in more detail and the process for our decisions recorded.

Testing has not actually been completed but the overall plan was written and organized for future use. We separated it into different levels so that it is easily followed for anyone to understand the rigorous process we went to ensure the system is working optimally. This is also covered in more detail in section 6.3 as seen below.

### 6.2 PCB Design

The overall PCB design can be seen in the figure below. Eagle was used to design the PCB and will continue to be used for improvements during senior design 2. Depth sensor design is not included in this overall design but will be included during SD2. This is because we will be approaching the design in 2 separate ways. We will either create a separate board for the depth sensor design or add it to the designed board that contains the MSP430 microcontroller. If we decide to create a separate board for the depth sensor, then we will be forced to add additional pin headers to the main PCB. This will be used to interface with the depth sensor PCB that will be created. An oscillator and Op amp will be needed on the main PCB if we decide to only use one PCB for the A.R.V. design. The schematic design and hardware design of the depth sensor can be seen in chapter 5 and will illustrate how it works.

For now, we will stick with one main PCB for the overall design of the Autonomous Rescue Vehicle. In the main board that is shown in the figure below, there will be footprints of the components that were put on the schematic, and pre wired connections from each pin out of all components. Each component will be purchased separately from TI, Digikey, and Mouser and must be soldered onto the board. Before this step, tests for functionality will be done using a

breadboard. These future system tests can be seen in a future section within this chapter.

The main component seen in the PCB design is the MSP430 footprint. This footprint contains all 80 pin outs of the microcontroller. Connections can be seen going to the pin header footprint for interfacing with the test, rest, rxd, and txd lines. This will be used for USB interface with a computer. A footprint with 14 pinout headers is used as shown in the bottom right. This footprint is important so that the board can be made with premade holes for soldering the pin headers.

Connections are also made for the GPS and Motor driver interfacing and connect to the pin headers pinouts 7-14. There are two 3.3V pinouts on the header that are required for powering on or sensors and a GND pin. This is shown connected to the output of the regulator footprint. The microcontroller requires many capacitors and many pins to be powered on with 3.3V. There is a requirement that the capacitors must be as close as possible to the microcontroller for each pin that has a 3.3V turn on. This is for limiting the current so that the pins don't get fried.

A crystal resonator is used for clocking purposes on the main board. This footprint can be seen in the bottom left side of the board and has 3 pin outs. The GND pad is on the head of the resonator and the 2 input pins are connected to the specific pinouts on the microcontroller. This oscillator requires 2 capacitors in parallel and must be as close as possible to its respective crystal. There are 3 pins on the microcontroller that require 3.3V and are all seen wired to the output of the regulator.

The output of the DC-DC converter contains a very large component. This footprint is the inductor needed for current limiting the regulator output. This also helps with the efficiency of the regulator. This footprint was appropriately placed in a way that helps maximize board space. Two footprints for the power in pads are placed on the top of the board. These will be used to solder on the 7.4V battery LiPo wires. All of the component names are also printed on the board for proper component placing when soldering. This will help us solder the correct component to the right pads.

Overall, this design is just the beginning of the main board. If possible, some of the sensors can be moved onto the main board which will help save space in the boat hull. However, this will create more wiring problems and can force us to create a second layer on the PCB design. More pin headers could be added in the future and the motor driver module can be replaced with just the main board. If this is the case, then this will require us to add an additional 5V regulator to the main board in order to turn on the H-bridge IC for the driver functionalities and interface. We will also add mounting holes on all four corners of the board and place pegs on these holes. This will allow the board to hover over the bottom of the boat so that a potential short from the bottom of the PCB is eliminated.



Figure 46: PCB Layout and Wired Connections

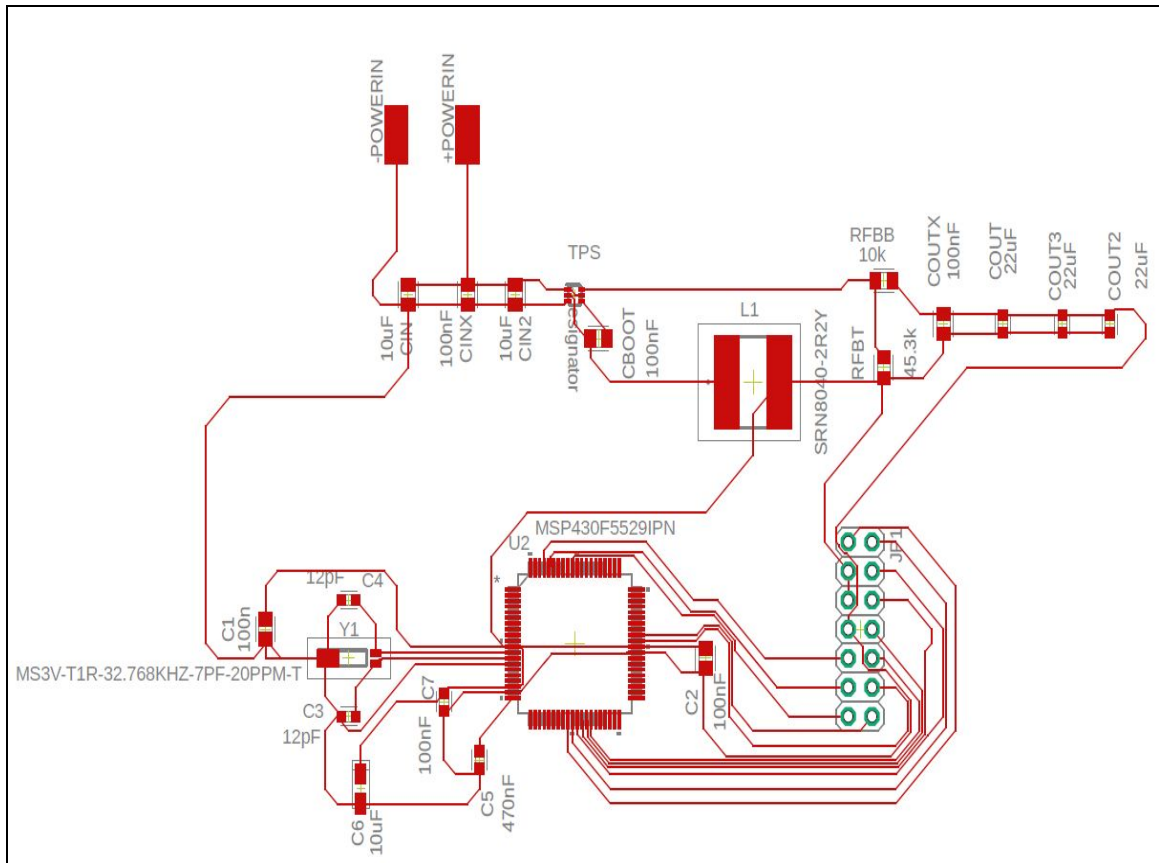

### 6.3 Project Prototype Illustration

Below is the prototype illustration of our completed project. As seen in the image we will be inserting all extra circuitry inside the interior of the hull, including our PCB, raspberry Pi and Battery. The location of these items in the interior is a rough estimate as we will most likely move them around to optimize our space and balance. The entire model can be adjusted in order to meet engineering requirements and marketing requirements. Additional modules will also be included within the prototype. This falls under the PCB category shown in the figure below. Although the camera is shown in the back, future models during senior design 2 might change this placement to the front of the boat for better object detection readings and better efficiency. Overall, this is not a final design and we will continue to make improvements based on testing and specific requirements.

Figure 47: Design Illustration

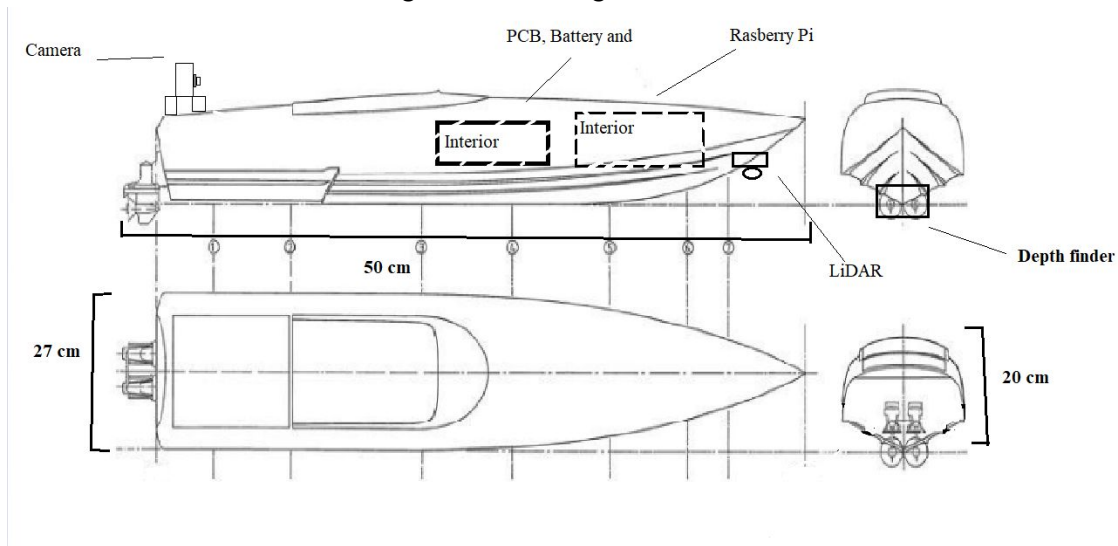

On the exterior of the boat we have both the measurement of the boat as is given in its data sheet, but also the placement of our exterior sensors. Most of the placement is fairly intuitive, the depth finder will be mounted on the bottom of the boat sealed in a watertight epoxy. This is so that we can aim the transducers towards the bottom of the water to receive our best ping possible. ( see section for more on the transducer)

Our raspberry Pi and PCB boards will both be located inside the sealed hull of our boat. The final placement for these will change as time goes on. This positioning will be finalized once we see where the pre positioned motors and circuit boards inside the boat are placed. The inside of the hull is water tight with a rubber sealant so there is no concern of the boards being damaged. ( see section for more on PCB and Raspberry Pi)

For our model of the boat there are small compartments for carrying cargo located on the rear of the boat. These will be removed making space for our camera, this is why they are not included in the diagram of our prototype. After these are removed there will be a small stand erect for the camera to go on top so that it has a clear field of sight for its image processing. ( for more information on the camera see section )

The last exterior sensor we are adding is the liDAR. This will be attached to the front of the boat pointing in the same direction as the camera. We do this so that we are sure they are looking at the same objects so that the liDAR can determine the shape and distance from the boat to the object it is. All wires and connections to these sensors will be fed into the hull so that they can connect to the microcontrollers. These holes will be sealed so as to guarantee the interior stays dry.

## 6.4 Project Operation Manual

The Automated Rescue Vehicle (A.R.V.) is an autonomous boat equipped with a camera, depth sensor, and LiDAR, with the purpose of being able to detect and identify objects or people in the water. When identifying an object, the A.R.V. would then notify the user that something has been detected along with displaying an image of said object, so that the user may respond accordingly. The initial setup process of the A.R.V. is relatively complex, but on subsequent uses, the startup becomes quite simple. The steps for first time use as well as subsequent uses are listed below.

In order to operate the A.R.V., there must be Wi-Fi within the area of use. While any Wi-Fi is sufficient, using a hotspot is preferred due to the mobile nature of the A.R.V. The same Wi-Fi network won't be available on different bodies of water, and in order to switch the Wi-Fi network that the A.R.V. is connected to, you must repeat the initial setup process. Because the initial setup process is rather complex, as stated previously, it's best to use a mobile hotspot, which can be brought to any body of water and makes use of the A.R.V. significantly more streamlined.

What makes the initial setup process more complicated is how the ESP8266 Wi-Fi module handles connecting to networks with the MSP430. The ESP8266 Wi-Fi module determines what network to connect to through the code uploaded to the MSP430, which means that in order to switch Wi-Fi networks on the A.R.V., the user must have the code on hand, edit the code to have the proper service set identifier (SSID or Network Name) and password, and upload it to the MSP430. Because the MSP430 is within the boat itself, this means that the boat must be opened.

The boat has two batteries within it: one 3.7 V battery for the Raspberry Pi, and one 7.4 V battery for the other components, which will need to be charged after use for a specified amount of time. The process for charging is also listed below.

### 6.4.1 Setup Process

This section will cover how to set up and interface with multiple of our sensors and the overall design of the autonomous rescue vehicle. It will show how users can set up tasks designated for wireless communication so that live streaming can be enabled and GPS data can be sent to a remote location. The below steps are critical for user operation and must always be followed for a better user experience.

### 6.4.1.1 Setting up A.R.V. Wi-Fi Network

Note that this process requires the Energia IDE installed on your computer.

- 1) To begin, open the boat by removing the four screws on the edges.
- 2) Once open, power on the A.R.V. by flipping the switch on the vessel to the ON position.
- 3) After turning on the A.R.V., connect the MSP430 to your PC and open the source code used for the MSP430.
- 4) Within the source code, navigate to the connectWifi() function.
- 5) Change the line `ESP.println("AT+CWJAP = /"SSID/",/"PASSWORD/")` by replacing the "SSID" with the Wi-Fi network name and the "PASSWORD" with the network password. Note that in the future, when changing the Wi-Fi network, instead of "SSID" and "PASSWORD", the line will contain the credentials of the Wi-Fi network that the A.R.V. was previously connected to.
- 6) Save, compile, and upload the code to the MSP430.
- 7) Disconnect the MSP430 from your PC.
- 8) Close the boat with the aforementioned screws. Be sure that the sealing on the edges of the boat are in their proper locations as to not damage the waterproofing of the boat. Refer to the section below regarding operation of the A.R.V. after the initial setup has been completed.

### 6.4.1.2 Steps for Normal Operation

- 1) Power on the A.R.V. by flipping the switch on the vessel to the ON position.
- 2) Place the A.R.V. in the water and go to "arvsd.com" on your browser of choice. The website displays the live feed of the A.R.V. as well as the data collected and the navigation options.
- 3) On the entries labelled "Latitude" and "Longitude", enter the coordinates you want the A.R.V. to travel to, or if you want it to navigate on its own, click the button labelled "Automated Search". If the camera spots a designated object, there will be a notification on the website.
- 4) For automated mode check the website for GPS data of longitude and latitude and be constantly aware of the live video being streamed for object detection. When an object is detected, the GPS location should already be displayed continuously updating on the website.

### **6.4.1.3 Step for Charging the A.R.V.**

- 1) Open the A.R.V. by removing the four screws on the edge.
- 2) With the charging station, connect the positive and ground terminals to the corresponding terminals of the batteries.
- 3) Power on the charging station and begin charging.
- 4) Once charging is complete, disconnect the charging station and close the boat with the aforementioned screws.

## **6.5 System Testing**

This section outlines important system testing that will take place during the actual build of the autonomous rescue vehicle. There is a lot of integration and components that will be tested during this process and will require various tests throughout the build. Hence, it is not plausible or a good idea to set up test requirements for a final product.

Testing should be completed gradually through each component and continued as other components are added to the system. Once the final step of the design is completed and all previous testing is done, an overall test run and setup can be run to ensure system functionality and final judgement. Hence, the following sections will outline different level testing that begin at a basic component level and end at the final system level.

### **6.5.1 Level 1 Testing**

Level one testing will include the initial testing of each of our singular parts purchased. Each part that we bought needs to be fully examined and tested to ensure basic working capabilities before moving forward with any of our design.

All sensors including the transducer SM111 and camera module need to be unboxed and checked for any obvious damage. Then the transducers will be attached to a function generator so that it can be provided a signal and amplitude easily. This will have the addition of a msp430 microcontroller and the required code to be tested for its ability to send and receive a signal properly. The camera will then be powered and reviewed for clarity as well as providing a basic picture to some display.

The PCB should also be checked for any damages and for correct padding orientations. A DMM can be used to ohm out different sections of the boards to make sure there are no shorts from any power to ground pins.

## **6.5.2 Level 2 Testing**

Next we will be checking the boat, this is also a very basic check for functionality. Taking the boat to any nearby water source we will be checking for speed floatation and control. Next the boat will be opened up and all circuits and batteries examined. Once we have the boat back together we will then check its abilities in the water to ensure there is no issue with leaks or any of the systems because we opened it up.

After these final run through of tests the boat is considered ready for its next implementation. At which point we will be able to test the code we will create. We want the boat to act autonomously so we will need to upload the needed code to the board and boat system to check its abilities. We check this first before any extra parts are added to ensure it functions safely before putting any more equipment at risk.

## **6.5.3 Level 3 Testing**

The GPS module is connected to the microcontroller and a computer to be tested. Need to go download and open the code composer and enter the code given by the website for your module. Then you run the test sequence given. The coordinates should be displayed onto the monitor of your computer inside the command window. Checking with google maps for accuracy we can compare the results to see how accurate our system is picking up the correct longitude and longitude.

## **6.5.4 Level 4 Testing**

The PCB board once it arrives will need examining for flaws but will soon after be ready for initial mounting of components. Each component will have had a designed connection area where it will be soldered. Firstly the oscillator and power amplifier will be soldered onto the PCB in their designated location. Then the lead wires will be soldered to the transducer and soldered to the microcontroller and PCB. We will then power the PCB with a simple battery just to test the transducer.

The transducers will be very apparent in the functionality because they will start to vibrate and make a lot of noise as they are intended. One they have been tested for power we will want to test the microcontrollers ability to compute the data it sends. To do this we will need the basic code for the system, we should be able to use a computer in the engineering lab to run the system and see the displayed values on the monitor.

### **6.5.5 Level 5 Testing**

Next we will need to write the code needed for the image processing. This will be run and compiled to ensure it runs correctly before integrating the camera into the raspberry pi. The raspberry pi will then have the code downloaded onto its system so it can take the images provided by the camera and run the processing we require. The camera will then be hooked up to the raspberry pi to show that it is able to be powered and receive information from the raspberry pi. Then we will run the image processing on some basic shape or item to prove its concept and the ability to handle more complicated imaging.

### **6.5.6 Level 6 Testing**

The next level will be the full assembly of the components. We will need to install all of the sensors to the PCB and have them permanently soldered on as well as having the camera soldered and connected to our raspberry pi. These will then need to have all of their final software downloaded and interfaced. After all of these are proven and tested to work in harmony outside the boat we are prepared to begin the entry inside the hull.

### **6.5.7 Level 7 Testing**

The sensors that will be on the outside of the boat will need to be waterproofed using the vytaflex polyurethane. We will need to mix the two parts and dip or insert the part. In the case of the transducer which you will need to have fully immersed you will need to ensure there are no air bubbles in the mixture. After this has been ensured we will need to rerun the test for the depth sensor to make sure it is still functioning optimally encased in the vytaflex. The camera will be inserted in a sealed clear box much like the go pro cases.

### **6.5.8 Level 8 Testing**

The hull will be opened up and the extra circuit cards will be inserted into the hull. This will have to be done carefully to ensure they all fit and can be ventilated so nothing overheats. At which point all boards will need to be securely mounted inside the hull and all wiring organized. The transducer will then be inserted through the bottom of the hull and its opening sealed. The camera will be mounted on the front of the boat on the outside, the wire that connects the camera to the raspberry pi must enter through the deck of the boat and this wire and hole must be sealed.

Once all of these components have been installed and properly connected we will be ready for our final test to ensure the functionality of our boat. We will be

testing the final product in the environment that we will be demonstrating it to ensure the best results. This will be the reflection pond in front of the UCF library. We will check every part of the system before launching the boat at which point we will go to the computer where all the data is to be displayed and check each individually for its display and accuracy.

### **6.5.9 Level 9 Testing**

The final level is to fully charge the boat and all batteries in the device and take the full system to the reflection pond at UCF. we will then boot up all systems on the boat and do one final technical check both with observations of the system and the computer values. Then the boat will be launched into the water and run autonomously.

All data it finds should be reported to the operation computer and a final test of the image processing should be given by placing an object in the reflection pond for the boat to find. Once the test is given and the boat finds the object and all data is reported to the computer system then our final testing should be completed, the boat can be considered fully operational after this last test.



## 7.0 Administration

### 7.1 Suppliers

Made it a point to make sure and get suppliers that are able to deliver in less than a week in case we need to order emergency replacements late into the project. All of these components with the exception of the flytech 2011-5 and the PCB. The boat should never need replacement as it is pre bought and assembled. The PCB of course takes awhile to receive because they have to build and then ship it, however we plan to get more than one copy of the board to ensure that we avoid any possible issues. Our primary suppliers are going to earn this title based mostly on the price and their availability. The secondary suppliers are to have in case they sell out at our primary supplier or if some unforeseen problem occurs.

Table 28: Suppliers List for all Components

Part name	Primary Supplier	Secondary Supplier
SM111	STEMiNC	Newark
VytaFlex 20	Smooth-On	---
Flytec 2011-5	Banggood	Wish
Raspberry Pi Camera	Amazon	Adafruit
NEO-6M GPS	Amazon	Newegg
Battery pack	Amazon	Newegg
Resistors x100	DigiKey	Newark
Capacitors x50	DigiKey	Newark
Inductors x50	DigiKey	Newark
PCB Assembly	IMI	Texas Instruments
Oscillator	Sitime	---
Wifi Module	Amazon	Banggood
Motor Driver	Amazon	---
Voltage amplifier	Piezo drive	DigiKey
Jumpers	Amazon	Green home fair
Raspberry Pi	Amazon	Adafruit

## 7.2 Estimated Project Budget and Financing

In most engineering projects 20 percent of the parts account for 80 percent of the total cost. This is a simple rule that governs projects not unlike Moores law, this project is no different. The financial discussion is more important than most engineers realize, because if it isn't cost effective it won't be built. Below is provided a table of all estimated costs in descending order of value. While ordering in bulk of 100 or 1000 components will reduce the price we are not interested in producing this item in bulk so we will have no way to reduce the price with bulk orders.

*Table 29. Estimated Item Cost*

<b>Item</b>	<b>Cost</b>
Voltage amplifier	\$88.00
Flytec HQ2011 RC boat (and remote)	\$125.00
Raspberry Pi Battery pack	\$25.00
Inductors x50	\$36.00
VytaFlex 20	\$28.35
Raspberry Pi Camera Module V2-8	\$27.01
Pcb Assembly	\$23.90
NEO-6M GPS Receiver Module	\$11.99
Resistors x100	\$10.00
SM111	\$9.95
Capacitors x50	\$8.50
Jumpers	\$7.49
RF 433MHz Module	\$4.95
Transmitter and Receiver	\$4.95
Oscillator	\$2.95
Transmitter and Receiver	\$4.95
Battery pack	\$2.00
Wifi Module	\$10.00
<b>Total</b>	

- In the case that we choose to design our own RC boat and only purchase the hull pre-made.
- Our project will be self funded with an initial budget of 600 USD. We are exploring 3rd party funding to subsidise this but it is unlikely in our current crisis.
- Below is an initial list of parts needed and a table of estimated costs.
- All values are subject to change as we will more than likely need to buy duplicates as the project unfolds.

## 7.2.2 Estimated Additional Costs

Additional costs are included in this report in case of a boat haul design. Depending on the suppliers selling RC boats, if it doesn't meet the project's needs, we must decide on designing our own boat. This will require additional costs and hence must be displayed in order to meet our cost requirement from chapter 2.

*Table 30. Additional Items for Boat Haul Method*

<b>Item</b>	<b>Cost</b>
Hull	\$34.99
35T Motor	\$25.99
Venom Group Venom 7.2V 3000mAh 6 Cell NiMH Battery	\$22.99
Double Sides Brushless ESC	\$16.39
Rudder	\$7.40
Propeller	\$6.58
Driveshaft	\$6.87
Servo	\$2.57
Venom Group Venom 7.2V 3000mAh 6 Cell NiMH Battery	\$26.51
<b>Total (New Total)</b>	<b>\$147</b>

## 7.3 Project Milestone for both semesters

This section outlines the milestones that will be achieved throughout the course of senior design 1 and 2. All of these milestones are extremely important and beneficial to our project because it keeps the team on track. It will help bring us effective time management skills and help us organize our time better. Staying on track with the milestones will help us build an overall efficient rescue vehicle and be prepared for the final presentation during senior design 2.

**(Red indicates UCF-imposed deadlines)**

5/29 – Divide and Conquer due

6/5 – Divide and Conquer V2 due

6/25 – Theoretical Project Design “relatively” finalized (We will have a strong idea of all, if not most, of the parts we need to build and complete the project, and we may begin ordering parts.)

7/3 – 60-Page Senior Design Draft due

7/8 – Parts acquired, Production Process begins

7/17 – 100-Page Report Submission due

7/22 – Final Document completed, Review and Finalization begins

7/26 – Final Document finalized

7/28 – Final Document due

8/5 – Depth-Sensing Boat 25% Completed

8/24 – Fall Semester Begins

8/31 – Depth-Sensing Boat Completed, Testing and Optimization begins, Consider adding additional features if all is going as planned

9/31 – All features finalized

11/10 – Testing and Optimization Completed, Project Finalized

## 8.0 Conclusion

The inception of the A.R.V. system was with interest to assist in an incredibly difficult, and very specific effort that saves lives. We began by identifying a serious problem that may affect anyone in the world either directly or indirectly. The vast majority of the world's population has either spent time on a water vessel or knows someone who has. There are also tens of millions of people who rely on large bodies of water for employment and survival. The ocean will never be tamed. We can only hope to further understand it, and continue to add to our tools that allow us to overcome its dangers. Despite our gross inability to naturally survive in a large body of water, humans will never stop relying on the seas for modern day survival. They are vital to commerce and travel. This faces rescue teams with the constant risk (and occurrence) of seaborne accidents and tragedies. It was our hope in taking a journey in creating the A.R.V to bring more safety to those in their ocean journeys.

We began by analyzing the overall task of an ocean search and rescue. The more eyes - the better. We decided to pursue the idea of adding a search device to the rescue team without taking away a pair of human eyes from scanning the vast water surface. The idea is attractive, but we kept in mind the option for manual control in order to ensure safe return and flexibility. Some of the obstacles we encountered were waterproofing, finding a medium for image transfer, communication range, and battery life. It was also a challenge finding the right boat that allowed for the addition of our components. The next obstacle was finding a boat that could ship to the team, as most boats are shipped from China. The pandemic has put shipping in a chokehold, which was also a concern for other components.

The component selection process called for three options to choose from for each major function. The Raspberry Pi quickly stood out as the most qualified candidate to handle the image processing, and the MSP430 became the right choice to regulate power, communicate with the GPS module, and be implemented on the PCB. The camera and GPS modules were quick decisions. There are numerous camera configuration options available, but the proprietary RPi camera module is optimized for working with its namesake board. Portable power for the Raspberry Pi became a rabbit hole of custom options, but we settled for a simple and effective battery pack that offers all necessary protection to the board.

Battery technology was heavily researched as well. Nickel Metal Hydride and Lithium-Ion Polymer seemed to go back and forth as NiMH took advantages in safety and ease of use, while LiPo took advantage in efficiency and weight. We chose to accept the responsibilities of LiPo, from proper charge/discharge and storage, to isolation in a wet environment.

There were thousands of options in selecting the RC boat itself, and even the option of building one from scratch. We decided to buy a built boat and focus on the electrical and computer engineering problems that would arise in the addition of components to meet the functionality requirements of the A.R.V. - rather than the mechanical and materials engineering problems that would arise in constructing an RC boat. The Flytec 2011-5 offered stand out features like a 500 meter control range, internal motors that control direction rather than a rudder, a viable deck area for the camera platform, and most importantly, the ability to open and reseal the body for the addition of components inside the boat. It is relatively large for an RC boat, which assured us that it would have ample room to house additional components.

Initial testing went smoothly for the components to be added, which will transform the RC boat to the A.R.V. The Raspberry Pi lived up to its legacy and was extremely user friendly, including setup for the camera module. The hardware setup for the Neo 6M GPS module was a challenge. The software setup for the communication to transmit the latitude and longitude information was done with the assistance of some example software provided by Arduino. Overall, this made the software setup much easier than attempting to piece together the right functions and syntax to get the code to run. The motor driver and JBtek power supply successfully provided safe power and control to the sample motor. The Raspberry Pi battery pack was extremely simple. It arrived 75% charged and simply plugged in and powered the board. The rest of the power system is implemented on the PCB design.

The main focus of the PCB design was the MSP430 footprint. We decided to lay a strong foundation with the PCB design that may stand alone or be built upon. The responsibilities associated with the image processing were given to the Raspberry Pi, which allowed us to confidently design a board to accommodate the supporting components. The PCB design is the most fluid step of this project. The design will be revisited, critiqued, and likely changed contingent upon further testing and implementation into the overall system. The PCB will have a diverse mix of functions, including voltage regulation, oscillation, and clock monitoring.

The A.R.V. proved to be a challenge worth pursuing. It has a strong purpose and realistic function. The dangers of ocean travel are ever present, from commercial and military, to tourism and private vessels. As a team, we identified and tackled a problem for the benefit of people all over the world. The hope is for the A.R.V to never be needed in an emergency situation, but accidents cannot be avoided. Estimated survival in warm waters with a life jacket is three to five days, disregarding sharks and dehydration. Every second counts, and every pair of eyes adds to the chances of recovering survivors. It was our mission with this project to make an advanced technological contribution to this effort.

## 9.0 Appendix

This chapter will show the bibliography and references made throughout the report. It will also show the approving messages and confirmation for allowing us to use copyright materials in this report such as diagrams and figures.

### 9.1 Bibliography

1. How to set up a static IP address on your Raspberry Pi. (2015, January 14). Retrieved July 4, 2020, from <https://thepihut.com/blogs/raspberry-pi-tutorials/16683276-how-to-setup-a-static-ip-address-on-your-raspberry-pi>
2. How to connect your Raspberry Pi to your iPhone WiFi hotspot via Raspbian Stretch Lite. (2018, July 27). Retrieved July 9, 2020, from <https://www.techcoil.com/blog/how-to-connect-your-raspberry-pi-to-your-iphone-wifi-hotspot-via-raspbian-stretch-lite/>
3. RPi-Cam-Web-Interface. (2020, May 22). Retrieved June 30, 2020, from <https://elinux.org/RPi-Cam-Web-Interface>
4. Sarkar, J., & Kumar, P. (2018, March 30). How to Connect ESP8266 to WiFi: A Beginner's Guide. Retrieved July 1, 2020, from <https://www.electronicshub.org/connect-esp8266-to-wifi/>
5. MSP430™ ultra-low-power sensing & measurement MCUs. (n.d.). Retrieved July 5, 2020, from <https://www.ti.com/microcontrollers/msp430-ultra-low-power-mcus/overview.html>
6. Maboshi. (2020, June 17). Arduino GPS Drone RC Boat. Retrieved July 25, 2020, from <https://www.hackster.io/maboshi/arduino-gps-drone-rc-boat-45d6f4>
7. Engineering Design and Practice Sequence (EDPS): EDPS-I Library Guide. (2020, March 12). Retrieved June 21, 2020, from <https://guides.library.queensu.ca/c.php?g=501793>
8. Datasheet Review: High-Performance STM32 Cortex-M4 Microcontroller. (n.d.). Retrieved July 3, 2020, from <https://www.hackster.io/news/datasheet-review-high-performance-stm32-cortex-m4-microcontroller-d1d6d07bea70>
9. McMillan, D. (2016). SeaCharger Oceangoing Autonomous Boat - Home. Retrieved July 16, 2020, from <http://www.seacharger.com/>
10. Portable Power for the Raspberry Pi. (n.d.). Retrieved July 09, 2020, from <https://www.raspberrypi.org/forums/viewtopic.php?t=36448>
11. O'Hara, T. (n.d.). *Navigating the Regulatory Maze of Lithium Battery Safety* [PDF]. Intertek.
12. Differences Between NiMH and LiPo Batteries. (n.d.). Retrieved June 22, 2020, from

- <https://www.eurorc.com/page/69/differences-between-nimh-and-lipo-batteries>
13. MIT, & AMS. (2016). Roboat project. Retrieved July 3, 2020, from <http://roboat.org/>
  14. IEEE Guide for the Characterization and Evaluation of Lithium-Based Batteries in Stationary Applications," in IEEE Std 1679.1-2017 , vol., no., pp.1-47, 31 Jan. 2018, doi: 10.1109/IEEESTD.2018.8262521.
  15. M, A. (2015, October 05). Batteries - NiMH Vs LiPo - Which is better? Retrieved June 22, 2020, from <https://hobbiesdirect.com.au/blog/nimh-vs-lipo-rc-batteries>
  16. ISO/IEC/IEEE International Standard - Systems and software engineering -- Software life cycle processes," in ISO/IEC/IEEE 12207:2017(E) First edition 2017-11 , vol., no., pp.1-157, 15 Nov. 2017, doi: 10.1109/IEEESTD.2017.8100771.
  17. MIT. (2013). MOOS-IvP. Retrieved July 16, 2020, from <https://oceanai.mit.edu/moos-ivp/pmwiki/pmwiki.php?n=Main.HomePage>
  18. IEEE Guide for Wireless Access in Vehicular Environments (WAVE) Architecture," in IEEE Std 1609.0-2019 (Revision of IEEE Std 1609.0-2013) , vol., no., pp.1-106, 10 April 2019, doi: 10.1109/IEEESTD.2019.8686445.
  19. TensorFlow Lite for Microcontrollers. (n.d.). Retrieved June 15, 2020, from <https://www.tensorflow.org/lite/microcontrollers>
  20. Open Robotics. (2010). Powering the world's robots. Retrieved July 25, 2020, from <https://www.ros.org/>
  21. Johnson, L. (2020, February 09). Real-time Object Tracking with TensorFlow, Raspberry Pi, and Pan-Tilt HAT. Retrieved June 12, 2020, from <https://towardsdatascience.com/real-time-object-tracking-with-tensorflow-raspberry-pi-and-pan-tilt-hat-2aeaef47e134>
  22. Last Minute Engineers. (2019, December 13). In-Depth: Interface L298N DC Motor Driver Module with Arduino. Retrieved July 13, 2020, from <https://lastminuteengineers.com/l298n-dc-stepper-driver-arduino-tutorial/>
  23. Pantech, S. (2015). Home. Retrieved July 2, 2020, from <https://www.pantechsolutions.net/mobile-phone-communication-with-micro-controller>
  24. Last Minute Engineers. (2019, December 13). In-Depth: Interface ublox NEO-6M GPS Module with Arduino. Retrieved July 19, 2020, from <https://lastminuteengineers.com/neo6m-gps-arduino-tutorial/>
  25. Piezo Material Properties. (n.d.). Retrieved July 19, 2020, from [http://www.steminc.com/piezo/PZ\\_property.asp](http://www.steminc.com/piezo/PZ_property.asp)
  26. EdjeElectronics. (n.d.). EdjeElectronics/TensorFlow-Object-Detection-on-the-Raspberry-Pi. Retrieved June 13, 2020, from <https://github.com/EdjeElectronics/TensorFlow-Object-Detection-on-the-Raspberry-Pi>



27. Hrisiko, J. (2019, April 23). Image Processing with Raspberry Pi and Python. Retrieved June 20, 2020, from <https://makersportal.com/blog/2019/4/21/image-processing-using-raspberry-pi-and-python>
28. Bluetooth, S. (2019). Core Specifications. Retrieved July 25, 2020, from <https://www.bluetooth.com/specifications/bluetooth-core-specification/>
29. Linear Regulator and Switching Regulator <What is the Difference Between Linear and Switching Regulators?>. (n.d.). Retrieved July 1, 2020, from <https://www.rohm.com/electronics-basics/dc-dc-converters/linear-vs-switching-regulators>
30. [https://www.banggood.com/URUAV-2011-5-Generation-50cm-Fishing-Bait-RC-Boat-500M-Remote-Fish-Finder-5\\_4km-or-h-Double-Motor-Toys-p-1281175.html?akmClientCountry=America](https://www.banggood.com/URUAV-2011-5-Generation-50cm-Fishing-Bait-RC-Boat-500M-Remote-Fish-Finder-5_4km-or-h-Double-Motor-Toys-p-1281175.html?akmClientCountry=America)
31. Miller, B. (2014, January 03). Creating a Speaker for Your Raspberry Pi Using a Piezo Element. Retrieved June 25, 2020, from <https://computers.tutsplus.com/articles/creating-a-speaker-for-your-raspberry-pi-using-a-piezo-element--mac-59336>
32. Linear and Switching Voltage Regulators - An Introduction. (2020, May 18). Retrieved July 8, 2020, from <https://predictabledesigns.com/linear-and-switching-voltage-regulators-introduction/>
33. Nilsson, N. J. (2015). Introduction to Machine Learning. Retrieved July 25, 2020, from <https://ai.stanford.edu/people/nilsson/mlbook.html>
34. Levine, Z. (2020, July 24). How to Build a Raspberry Pi UPS (Uninterruptible Power Supply). Retrieved July 3, 2020, from <https://howchoo.com/g/ntfiytbjote/raspberry-pi-ups-uninterruptible-power-supply>
35. Fisher, A. (2017, June 03). The Drone That Will Sail Itself Around the World. Retrieved June 12, 2020, from <https://www.wired.com/2014/02/saildrone/>
36. MAC, I. (2016). Wifi Connectivity Explained. Retrieved July 25, 2020, from <https://www.macinstallations.com/wifi-connectivity-explained/>
37. SONAR Equation. (2018, December 19). Retrieved July 25, 2020, from <https://dosits.org/science/advanced-topics/sonar-equation/>
38. (n.d.). Retrieved June 15, 2020, from <https://www.google.com/search?q=first+time+sonar+was+used+for+finding+depth>
39. (n.d.). Retrieved June 30, 2020, from <https://www.google.com/search?q=vytaflex+rubbers>
40. Ceramics, S. (n.d.). Piezo Ceramic Disc 10x3mm R 215 KHz. Retrieved June 25, 2020, from <https://www.steminc.com/PZT/en/piezo-ceramic-disc-10x3mm-r-215-khz>

41. Underwater Acoustics. (n.d.). Retrieved June 28, 2020, from <https://www.sciencedirect.com/topics/earth-and-planetary-sciences/under-water-acoustics>
42. GPS Receiver Module: Sensors & Modules. (n.d.). Retrieved July 13, 2020, from <https://www.electronicwings.com/sensors-modules/gps-receiver-module>
43. GPS Module Interfacing with MSP-EXP430G2 TI Launchpad: TI Launch.. (n.d.). Retrieved July 2, 2020, from <https://www.electronicwings.com/ti-launchpad/gps-module-interfacing-with-msp-exp430g2-ti-launchpad>
44. Robots, S. (2014). How to Build a Robot Tutorials. Retrieved June 18, 2020, from [https://www.societyofrobots.com/microcontroller\\_uart.shtml](https://www.societyofrobots.com/microcontroller_uart.shtml)
45. ProjectPayload, & Instructables. (2017, September 29). Raspberry Pi GPS Tracker. Retrieved July 12, 2020, from <https://www.instructables.com/id/Raspberry-Pi-GPS-Tracker/>
46. Limited, E. (2018, December 04). Principles of PID Control and Tuning. Retrieved July 14, 2020, from <http://www.eurotherm.com/temperature-control/principles-of-pid-control-and-tuning/>
47. NEO-6M GPS Module - An Introduction. (2019, April 04). Retrieved July 12, 2020, from <https://www.electroschematics.com/neo-6m-gps-module/>
48. Installing Sparkfun and Adafruit Libraries: EAGLE: Blog. (2017, March 08). Retrieved July 20, 2020, from <https://www.autodesk.com/products/eagle/blog/library-basics-install-use-sparkfun-adafruit-libraries-autodesk-eagle/>
49. Peck, J. (n.d.). Popular Science. Retrieved May 28, 2020, from <https://books.google.com/books?id=bCEDAAAAMBAJ>
50. Posted by alex at 6:03 am. (2019, June 25). How much power does the Pi4B use? Power Measurements. Retrieved June 5, 2020, from <https://raspi.tv/2019/how-much-power-does-the-pi4b-use-power-measurements>

## 9.2 Permissions



### \* Inquiry

I wanted to request permission to use some of your figures on your website for my senior design report for school. Please let me know if its ok to use them.

Full Name: Bernardo Correa \*

Email Address: bernardocorrea@knights.ucf.edu \*

Confirm E-Mail: bernardocorrea@knights.ucf.edu \*

Category: Press / media inquires v

Please supply a detailed description of your press/media inquiry in the form below, or email us directly. At this time the Adafruit team and our founder Limor "Ladyada" Fried is booking new speakers.

Hello,  
I am a student at the University of Central Florida. I wanted to ask for permission to use some of your product pictures in my Senior Design Report. We will be using your products in our project.  
  
Thank You,  
Bernardo Correa

Send Message

Mailing address: Pi Supply, Unit 4 Bells Yew Green Business Court, Bells Yew Green, East Sussex, TN3 9BJ, United Kingdom. Support requests: Before you create a new support request you might want to check our Maker Zone area... I am requesting permission to use the photo of the PiJuice HAT from the product page for my senior design report. Thank you!

MS Malik Santos Fri 7/24/2020 10:22 PM To: primary@amazon.com I am requesting permission to use the image of the battery pack in the following URL in my senior design report. https://www.amazon.com/MakerHawk-Raspberry-Uninterruptible-Management-Expansion/dp/B082CVWH3R Best regards, Malik Santos



phillip torrone <pt@adafruit.com>

Wed 7/1/2020 10:30 PM

To: Bernardo Correa

this is all good, please do.

Will do, thanks!	Thank you!	Will do.
------------------	------------	----------

Are the suggestions above helpful? Yes No

> On Jul 1, 2020, at 8:29 PM, Bernardo Correa <contact\_us\_forms@adafruit.com> wrote:  
 >  
 > contactname : Bernardo Correa  
 > email address : bernardocorrea@knights.ucf.edu  
 > message text : Hello,  
 > I am a student at the University of Central Florida. I wanted to ask for  
 > permission to use some of your product pictures in my Senior Design Report.  
 > We will be using your products in our project.  
 >  
 > Thank You,  
 > Bernardo Correa  
 > Client IP: 2603:9001:2806:a2a1:112e:90a5:9cd4:1e7c



Malik Santos

Wed 7/15/2020 10:59 PM

To: verkauf@distrelec.de



Hello,

I am requesting **permission** to use the image of the STM32 in the following URL in my senior design report.

<https://www.distrelec.de/en/discovery-kit-stm32-development-board-arm-cortex-m4-st-stm32mp157c-dk2/p/30176636>

STM32MP157CDK2 Discovery Kit STM32 Development Board, ARM® Cortex® M4, ST

Next-day delivery! Buy Discovery Kit STM32 Development Board, ARM® Cortex® M4, in the Distrelec Online Shop | We love electronics

[www.distrelec.de](http://www.distrelec.de)

Best regards,  
Malik Santos



Malik Santos  
 Fri 7/24/2020 10:19 PM  
 To: orders@makerfocus.com



I am requesting permission to use the image of the battery pack in the following URL in my senior design report.

<https://www.makerfocus.com/collections/rpi-module/products/raspberry-pi-expansion-board-ups-pack-standard-power-supply>



Best regards,  
 Malik S.

Permission to use image



**Daniel Tenf** <dtenf816@gmail.com>  
 to contact

Tue, Jul 21, 7:15 PM (3 days ago) ☆ ↶ ⋮

Hello,  
 My name is Daniel Tenf. I'm a Computer Engineering student at the University of Central Florida. I would like to request permission to use images of the SeaCharger for a report I am writing for Senior Design. Your permission would be greatly appreciated.

Thank you,  
 Daniel Tenf



contact@seacharger.com

Permission to use image Inbox x



**Daniel Tenf** <dtenf816@gmail.com>  
 to contact

Tue, Jul 21, 7:11 PM (3 days ago) ☆ ↶ ⋮

Hello,  
 My name is Daniel Tenf. I'm a Computer Engineering student at the University of Central Florida. I would like to request permission to use images of the Roboat for a report I am writing for Senior Design. Your permission would be greatly appreciated.

Thank you,  
 Daniel Tenf



**Fabio Duarte** <fduarte@mit.edu>  
 to me, contact@roboat.org

Tue, Jul 21, 9:04 PM (3 days ago) ☆ ↶ ⋮

Dear Daniel  
 Thank you for your interest in Roboat.  
 We have the permission to use the image in your report as long as it is duly credited as a project by MIT and AMS Institute.  
 Best regards

--  
**Fábio Duarte**  
 Principal Research Scientist  
 Senseable City Lab  
<http://senseable.mit.edu>  
  
 Lecturer  
 Department of Urban Studies and Planning  
 Massachusetts Institute of Technology

## Messages / Permission to use image

Delete 

 **Dariel Tenf**  
3 days ago

Hello,

My name is Dariel Tenf. I'm a Computer Engineering student at the University of Central Florida. I would like to request permission to use images of the Arduino GPS Drone RC Boat for a report I am writing for Senior Design. Your permission would be greatly appreciated.

Thank you,  
Dariel Tenf

 **maboshi**  
3 days ago

Sure no problem  
Von meinem iPhone gesendet

Write your message

Send reply

### Picture Use **Permission** [ ref:\_00Do0aduJ\_5001JwRKi4:ref ]



**noreply@salesforce.com** on behalf of CSR <cservice@sparkfun.com>  
Thu 7/16/2020 11:14 AM  
To: Malik Santos

Hello,

Thank you for reaching out to SparkFun! As an open source company we allow usage of anything we post online under the creative commons statute and only request that you provide us with the credit for the original work.

Please let us know if there is anything else that we can help you with.

Have a great day!  
Aubrey  
Customer Service Representative  
SparkFun Electronics  
www.sparkfun.com <<http://www.sparkfun.com>>

----- Original Message -----  
From: Malik Santos [[msantos98@knights.ucf.edu](mailto:msantos98@knights.ucf.edu)]  
Sent: 7/15/2020 8:50 PM  
To: [website@sparkfun.com](mailto:website@sparkfun.com)  
Subject: Picture Use **Permission**

Hello,

I am requesting **permission** to use the image of the Raspberry Pi 4 in the following URL in my senior design report.

<https://www.sparkfun.com/products/15447>

Best regards,  
Malik Santos

**E** Electronics-Lab.com <info@electronics-lab.com>  
Thu 7/16/2020 4:58 AM  
To: Malik Santos

Yes, you can use it.

**Michail Papadimitriou** · Founder / Editor  
skype [michail.papadimitriou](#) | m +30 6944 715554  
e [info@electronics-lab.com](mailto:info@electronics-lab.com) | w [www.electronics-lab.com](http://www.electronics-lab.com)



**MS** Malik Santos  
Wed 7/15/2020 10:43 PM  
To: info@electronics-lab.com

Hello,

I am requesting **permission** to use the image of the MSP430 in the following URL in my senior design report.

<https://www.electronics-lab.com/brief-introduction-msp430-using-launchpad-msp430g2553/>



An Introduction to MSP430 Launchpad - Electronics-Lab

Mike is the founder and editor of Electronics-Lab.com, an electronics engineering community/news and project sharing platform. He studied Electronics and Physics and enjoys everything that has moving electrons and fun.

[www.electronics-lab.com](http://www.electronics-lab.com)

**R** Rebekah Frank <RebekahF@ultralibrarian.com>  
to Info@UltraLibrarian, me ▾

Hi Samuel,

Thank you for contacting the Ultra Librarian team.

You can certainly use the Ultra Librarian logo in your research paper! In fact, we would love to see the finished paper and, if you are amicable, perhaps write a profile on it on our site!

Best regards,  
Rebekah

**STEMINC - SALES**  
to me ▾

Good Morning Samuel,

Thank you for your reply.  
Yes you can use it. Please mention the part number and the name Steminc.  
Good luck with your research paper!

...

**Fearles Fuego**  
Jul 21, 2020, 6:48 PM PDT

Theres a picture of your boat, the flytex2011-5. I would like to use the picture of that boat in my reaserch paper sense we are using it for our capstone project

**Fearles Fuego** <samfranfrisco989@gmail.com>  
to dreamzs338 ▾

hey id like to use one of your images for a research paper discussion for college





**Fearles Fuego**

id like to use a picture of the eagle software logo for a research paper at college

---

**Getty Images** autoresponse.gi@gettyimages.com [via jfi1xqkffwj7h.41-6f87eaa.na129.bnc.salesforce.com](#)  
to me ▾

Hello,

Thank you for your inquiry, we are tracking it under the reference number 01998909 for you.